

**AKO-16524A AKO-16525A AKO-16525AN**

Advanced temperature controller for cold rooms

User manual

**AKO**

Index	Page
Presentation.....	3
Warnings .....	3
Maintenance.....	3
Description.....	4
Installation.....	6
Wiring.....	7
Installation of the CAMM AKO-58500 * .....	9
Link with the AKO CAMM Tool / AKO CAMM Fit application * .....	9
Initial configuration (wizard).....	10
Operation.....	12
Configuration.....	31
Connectivity .....	37
Technical specifications.....	38
Troubleshooting .....	39
Simplified declaration of conformity.....	39

AKO Electromecánica thanks and congratulates you for purchasing our product, in whose development and manufacture the most innovative technology has been used, as well as strict production and quality control processes.

Our commitment to satisfy our customers and our continuous efforts to improve every day can be seen in the various quality certifications we have obtained.

This is a high performance, high technology product. The operation and final performance of the equipment depend on proper planning, installation, configuration and commissioning. Read this manual carefully before installation, and always follow its instructions.

Only qualified personnel should install or perform technical assistance on this product.

This product is designed to be used in the applications described in the product manual. AKO Electromecánica gives no guarantee of its operation in any use not foreseen in the manual, and is not responsible for any damage resulting from improper use, configuration, installation or commissioning.

It is the responsibility of the installer and the customer to comply with and ensure others comply with all regulations applicable to installations incorporating our products. AKO Electromecánica is not responsible for any damage caused by non-compliance with regulations. Follow strictly the instructions given in this manual.

To maximise the service life of our equipment, these recommendations should be followed:

Do not expose electronic equipment to dust, dirt, water, rain, humidity, high temperatures, chemicals or corrosive substances of any sort.

Do not submit the equipment to blows or vibrations nor try to manipulate it differently from shown in the manual.

Never exceed the specifications and limitations indicated in the manual.

Always respect the specified ambient working and storage conditions.

During and after installation, avoid leaving loose, broken, unprotected or damaged wiring, since they might constitute a risk for the equipment and its users.

AKO Electromecánica reserves the right to make any non-metrology modification to the documentation or the equipment without previous notice

## Presentation

The **AKO-16524A / 16525A / 16525AN** advanced controllers for cold room stores has a SELFDRIVE operating mode that automatically controls (without parametrisation) the fans and adaptively minimises defrosts to optimise the performance of the cold room store: maximising time in set point and minimising costs linked to energy consumption and wear of components.

The **AKO-16524A** controller includes the CAMM module (AKO-58500), which, together with the mobile apps AKO CAMM Tool and AKO CAMM Fit (available on the App Store and Google Play), is intended to evaluate the performance of the refrigeration system in detail. These applications provide several indicators on the actual operation of the cold room that allow diagnosing possible design, usage or maintenance problems in the installation.

The **AKO-16525AN** controller incorporates a NBIoT communication module that allows it to send operation data to akonet.cloud autonomously.



## Warnings



-If the equipment is used without adhering to the manufacturer's instructions, the device safety requirements could be compromised. Only probes supplied by AKO must be used for the unit to operate correctly.

- From -40 °C to +20 °C, if the NTC probe is extended to 1000 m with at least a 0.5 mm<sup>2</sup> cable, the maximum deviation will be 0.25 °C (cable for probe extension ref. AKO-15586. Earth the cable mesh at one end only).
- Only NTC type probes supplied by AKO must be used for the appliance to operate correctly.
- It must be installed in a place protected from vibrations, water and corrosive gases, where the ambient temperature does not exceed the value indicated in the technical data.
- For the reading to be correct, the probe must be used in a place without thermal influences apart from the temperature you want to measure or control.
- IP65 protection degree is only valid with the protection cover closed.
- The IP65 protection degree is only valid if the cables enter the device through a tube for electric conduits + gland with IP65 or above. The size of the glands must be suitable for the diameter of the tube used.
- Do not spray the unit directly with high-pressure hoses, as this could damage it.
- This device must be installed in a location where a minimum distance of 20 cm to the human body can be guaranteed, in order to ensure compliance with standards on human exposure to electromagnetic fields.
- The **AKO-16525AN** device must **NEVER** be operating without the internal antenna. This device can be fitted with any antenna provided it has a gain of less than 9.2 dBi and there is a minimum distance of more than 20 cm between it and any person or animal. Any type of antenna used with this device must comply with the limits established for the radio interface in Member States and the following documents: Commission Decision 2010/267/EU of 6 May 2010, ECC Decision (09)03 of 30 October 2009 and CEPT Report 30 of 30 October 2009.

## Maintenance







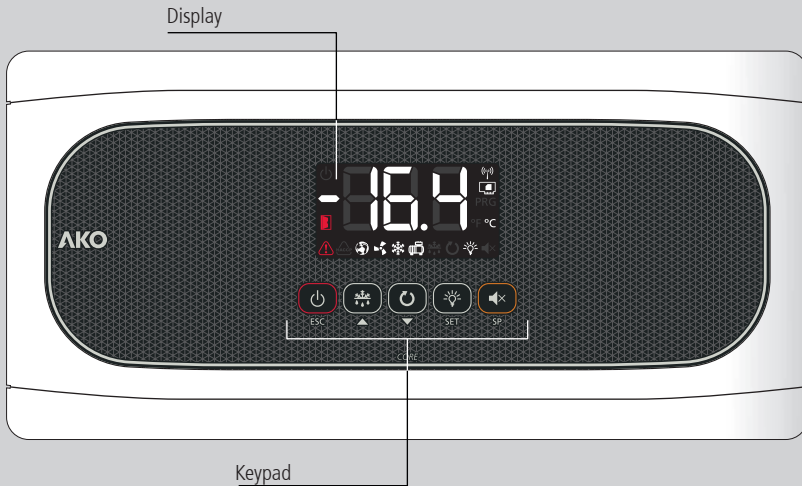







Clean the surface of the unit with a soft cloth, water and soap.

Do not use abrasive detergents, petrol, alcohol or solvents, as this might damage the unit.

## Description



### Indicators

- 
**Constant:** Stand-By Mode activated. Regulation is paused.  
**Flashing:** Controlled stop process for the regulation in progress.
- 
**Constant:** Cold room door open.  
**Flashing:** The door has been open for a longer time than defined in parameter **A12**.
- 
 There is an active alarm, but not an active HAC-CP alarm.
- 
**Constant:** HACCP alarm active.  
**Flashing:** HACCP alarm recorded and unconfirmed. Press the  key to confirm an HACCP alarm.
- 
**Constant:** The SELFDRIIVE mode is active.  
**Flashing:** An error has been detected in the SELFDRIIVE mode.
- 
**Constant:** Evaporator fans active.  
**Flashing:** The evaporator fans should be active but a delay is preventing this.
- 
**AKO-16524A, AKO-16525A:** Bluetooth activated (only with CAMM module).  
**AKO-16525AN :** **ON:** Device registered on the NBloT network and with a valid licence.  
**OFF:** Unable to register on the NBloT network or the licence has expired.
- 
**Constant:** The cold solenoid is active.  
**Flashing:** The solenoid should be active but a delay or protection is preventing this.
- 
**Constant:** Compressor active.  
**Flashing:** The compressor should be active but a delay or protection is preventing this.
- 
 Defrost relay active.
- 
 Continuous cycle mode active.
- 
 Cold room light active.
- 
 Alarm in progress muted.
- °F °C Temperature displayed in ° Fahrenheit / ° Centigrade.
- PRG** Programming mode active.
- 
**Constant:** CAMM module in operation.  
**Flashing:** Malfunction in CAMM module.

## Keypad



ESC

Pressing it for 3 seconds activates/deactivates the Stand-By mode. In this mode, regulation is paused and the  icon is displayed.

In the programming menu, it exits the parameter without saving changes, returns to the previous level or exits programming.



▲

Pressing once without holding displays the temperature of probe S2 for 2 seconds (if it is enabled).

Pressing it for 3 seconds starts/stops the defrost.

In the programming menu, it allows scrolling through the different levels, or during the setting of a parameter, changing its value.



▼

A brief press shows the SELFDRIIVE mode operating alerts.

Pressing it for 3 seconds activates/deactivates the continuous cycle mode.

In the programming menu, it allows scrolling through the different levels, or during the setting of a parameter, changing its value.



SET

Pressing once without holding activates/deactivates the cold room light.

Pressing it for 3 seconds accesses the condensed programming menu.

Pressing it for 6 seconds accesses the expanded programming menu.

In the programming menu, it accesses the level shown on the display or, during the setting of a parameter, accepts the new value.



SP

Pressing once without holding displays the current effective value of the Set Point, taking into consideration temporary modifications by other parameters (C10 or C12).

When an alarm is in progress, pressing once without holding mutes the acoustic alarm.

Pressing for 3 seconds accesses the Set Point setting.



ESC

+



SET

**Only AKO-16525AN:** Pressing the **SET** and **ESC** buttons for 3 seconds forces the transmission to the cloud via NBloT connectivity.

**STAND-BY**

If the regulation cannot be instantly stopped due to its configuration, a controlled stop process starts and the  icon flashes. To stop the controlled stop process and force the step to Stand-by, press the Stand-by key again for 3 seconds.

## Installation

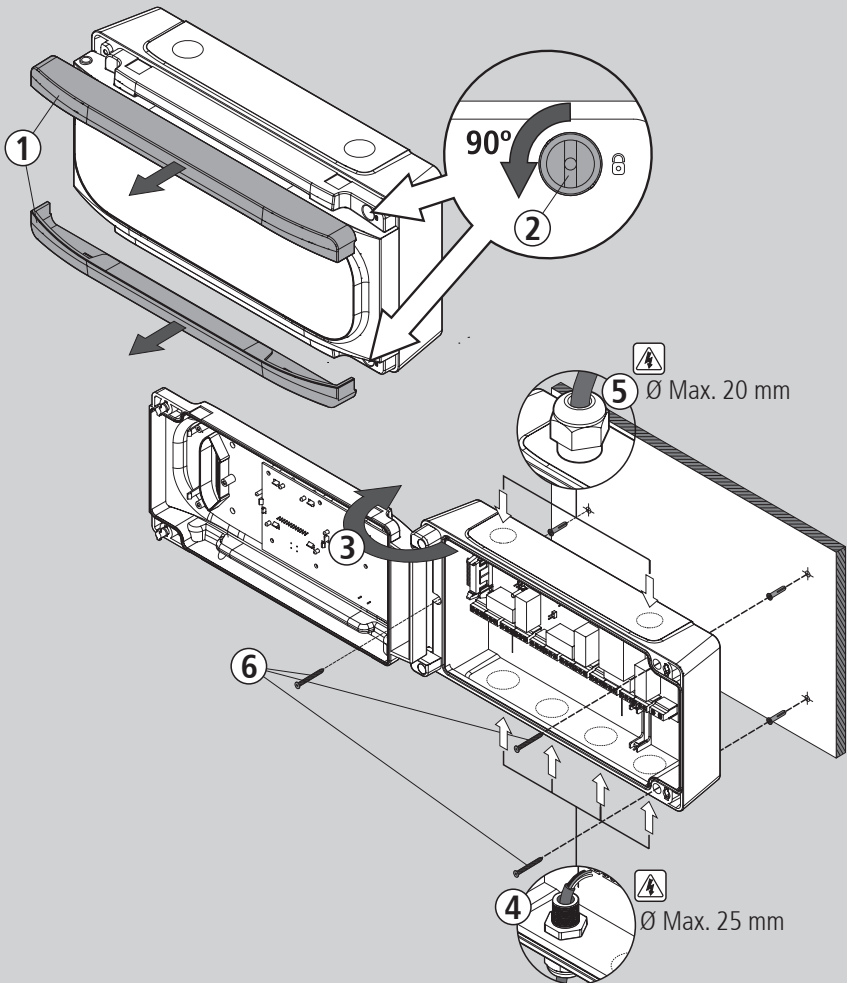

- Remove the bezels (1)
- Make a 1/4 turn of the screws (2) anti-clockwise and open the door (3).
- Install the necessary glands (4 / 5) by drilling holes in the points indicated on the box.
- Mark and make the holes in the wall with the aid of the template included.
- Fix the device to the wall. If it is a brick wall, use the screws and plugs supplied; if the wall is made of sheet metal (cold room store), use the screws provided without plugs (6).
- Wire the device by following the recommendations indicated on page 7.
- Close the cover (3), tighten the screws (2) and replace the bezels (1).



**ATTENTION:** When drilling the holes for the glands, take care to avoid damaging the internal components.  
**AKO-16525AN: DO NOT DRILL ANY HOLES IN THE TOP OF THE DEVICE.**

## Wiring



Always disconnect the power supply to do the wiring.

The probes and their cables must **NEVER** be installed in a conduit together with power, control or power supply cables.

For disconnection, the power supply circuit must be equipped with at least a 2 A, 230 V switch, located near the device. The power supply cable shall be of the H05VV-F or NYM 1x16/3 type. The cross-section to be used will depend on the local regulations in force, but must never be less than 1.5 mm<sup>2</sup>.

Cables for relay or contactor outputs must have a cross-section of 2.5 mm<sup>2</sup> and allow working temperatures equal to or over 70 °C and must be installed with as little bending as possible.

The 120/230 V~ wiring area must be kept clear of any other external element.

**The wiring to be undertaken depends on the option selected in the initial configuration wizard (see page 10). Use the appropriate diagram based on the option selected.**

**Check the available options on the diagram sheet included with your device.**

The **AKO-16523D** model has a contactor which allows for the connection of three-phase defrost resistors, a three-phase compressor or three-phase fans, according to your installation's requirements. Check how to connect it on the diagram sheet included with your device.

**IMPORTANT:**

- The AUXILIARY relays are programmable, and their operation depends on the configuration.
- The function of the digital inputs depends on the configuration.
- The recommended currents and powers are the maximum working currents and powers.

## Installation of the probes

To achieve maximum performance from the advanced controller, the correct installation of the probes is key, as they are responsible for calculating the evaporator's thermal transfer coefficient, evaluating the start and end of the defrosts and diagnosing problems in the evaporator.

### Material included

- 5 mm hermetic evaporator probe, 1.5 m of cable.
- Ambient probe
- 1 mounting clip for 10-13 mm coil
- 1 mounting clip for 14-18 mm coil
- 1 mounting clip for 19-21 mm coil
- 1 mounting clip for 22-25 mm coil

### Location of the ambient probe

The probe should be located in a place that does not directly receive the flow of cold air from the evaporator. Preferably in its air aspiration area.

### Location of the evaporator probe

The probe must be located as near as possible to the inlet of refrigerant from the evaporator (close to the expansion valve) in the finned area.

In certain evaporators, for example cubic ones, this inlet may be located on the front part of the battery, just behind the fan.

If defrost is done by electric heat, the probe must be located far away from them and, if possible, in the area of the evaporator where defrosting is slower, in other words, in the last area to defrost.

If the two conditions are not possible, the best possible compromise must be looked for.

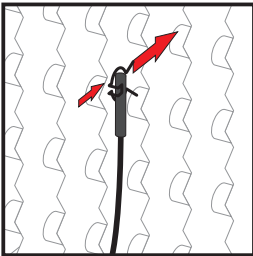

Select the appropriate clip depending on the size of its evaporator pipe.

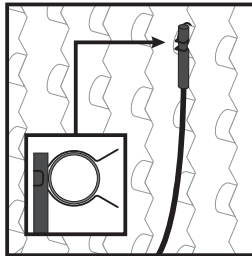

Attach the probe to the pipe using the clip, making sure that its end is in direct contact with the tube.

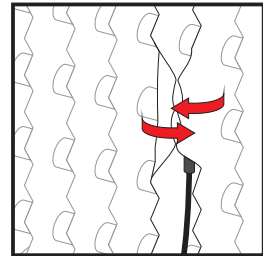

Bend the fins of both ends of the probe to increase the fixing and contact surface.

## Installation of the CAMM AKO-58500 \*

Insert the CAM **AKO-58500** module in the pre-installed base as shown in the picture.

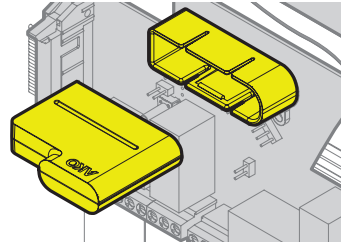

In combination with the application for AKO CAM Tool mobile devices, the CAM module provides the device with multiple functions:

- Data logging
- Logging of configuration changes
- Remote configuration
- Clock functions in real time
- Activity summaries
- Logging of events and alerts
- Remote control of functions
- Energy efficiency indicators

## Link with the AKO CAMM Tool / AKO CAMM Fit application \*

The use of both applications requires logging in with a valid email.

**i** After 1 minute without activity between the application and the CAMM module, communication is disconnected, to re-establish it, return to screen "Device list" and press the **FE** button.

**1** Open app AKO CAMM Tool / AKO CAMM Fit in your mobile and enter the access data.



**2** The app makes a device search and displays the results on screen.



Choose the device you want, in a few seconds the app requests the Bluetooth link code (by default 123456).

**3** After a few seconds, the app displays the screen of the device chosen, communication has been established correctly.



**i** Some Android devices, during the linking process, may tell the user to access settings / Bluetooth and link from there, looking for the device via its serial number.

\* Not available in **AKO-16525AN**

## Initial configuration (wizard)

The first time the unit receives the power supply, it will enter into AS-SISTANT mode. The display will show the message *ini* flashing at **0**.

### Step 1:

Select the most suitable *Ini* option based on the type of installation to be carried out and press **SET**. The available options will be shown in the following table:

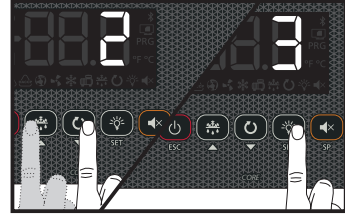

ini	Type of installation				Parameters									Diagram to be used	
	Cold regulation	Pump Down	Defrost	Evaporator fans	Pd	o00	l00	l10	l11	l20	l21	d1	d7		F3
<b>0</b>	Demo mode: it displays the temperature but does not regulate the temperature or activate relays.														
<b>1</b>	Solenoid	No	Eléctrico	Yes	0	0	2	0	0	0	0	20	0	0	A
<b>2</b>	Solenoid + compressor	Yes	Eléctrico	Yes	1	1	2	7	1	0	0	20	0	0	B
<b>3</b>	Solenoid + compressor	No	Eléctrico	Yes	0	1	2	0	0	0	0	20	0	0	B
<b>4</b>	Solenoid	No	Aire	Yes	0	0	2	0	0	0	0	20	1	1	A
<b>5</b>	Solenoid + compressor	Yes	Aire	Yes	1	1	2	7	1	0	0	20	1	1	B
<b>6</b>	Solenoid + compressor	No	Aire	Yes	0	1	2	0	0	0	0	20	1	1	B
<b>7</b>	Solenoid + compressor	Yes	Hot gas	Yes	1	1	2	7	1	9	1	5	2	0	C
<b>8</b>	Solenoid + compressor	No	Hot gas	Yes	0	1	2	0	0	9	1	5	2	0	C

**i** If options 2, 5, or 7 are chosen, check the configuration of parameter **l11** according to the pressure switch type used. (See diagram included with the device).

### Step 2:

Use keys **▲** and **▼** to enter the desired Set Point value and press **SET**. The configuration wizard has finished. The unit will begin to regulate the temperature.

If this is not the first time you run the wizard, after completing the last step the display will show the message **dFP** (default parameters). You may choose between two options:

- 0**: Only change the parameters which affect the wizard. The other parameters will remain the same.
- 1**: All parameters return to their factory setting except those which have been modified by the wizard.

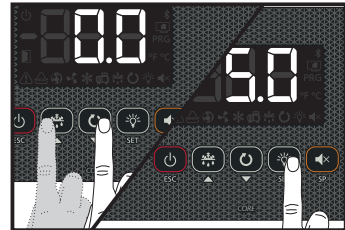



**i** **The configuration wizard will not reactivate.** To reactivate it, activate the Stand-By mode (by pressing the **⏻** key for 3 seconds) and wait until the unit completely halts regulation (the **⏻** indicator will light up permanently) and press in this order the following keys (one after the other, not at the same time) **▲**, **▼** and **SET**.

**⚠** **STAND-BY**  
If the regulation cannot be instantly stopped due to its configuration, a controlled stop process starts and the **⏻** icon flashes. To stop the controlled stop process and force the step to Stand-by, press the Stand-by key again for 3 seconds.

## Registration on akonet.cloud (only AKO-16525AN)

In order for the controller to be able to send operation data to akonet.cloud, it must be registered.

To do this, go to <https://akonet.cloud> (requires registration), click on "Add new device"  and continue with one of these two methods:

- Enter the serial number (S/N) and validation code / IMEI that appear on the tag and press "Search".
- Capture the QR code that appears on the tag using the  option (requires having a camera on your PC, tablet or mobile phone).

These data are found on the tag on the right hand side of the controller. More information can be found in the akonet.cloud user guide at: "<https://enhelpakonet.ako.com/>"

To access akonet.cloud, enter this address in your browser (the use of Google Chrome is recommended): <https://akonet.cloud>.



Before activating the device, make sure that there is enough reception at the installation location. Activated devices may not be returned.

### Forcing transmission

When the steps of the configuration wizard and the registration process are completed in akonet.cloud, you must force a first transmission to verify the level of reception:

Press and hold the **ESC** and **SET** keys for 3 seconds.

After a moment, the display shows the quality of the NBloT signal received:

Low quality



Medium quality



High quality



Communication error



The controller does not start transmitting data to akonet.cloud until the first transmission is forced.

## Operation

MESSAGES	
	Pump down malfunction error (stop), the time configured in parameter C20 has been exceeded (see page 18). Only displayed on screen.
	Pump down malfunction error (start-up), the time configured in parameter C19 has been exceeded (see page 18). Only displayed on screen.
	Probe 1/2/3 failure (open circuit, crossed circuit or temperature outside the limits of the probe) (Equivalent limits in °F). Only E2 and E3: Damp evaporator probe (see page 26). Activates the alarm relay and the audible alarm. <b>Flashing with temperature:</b> Probe error 1/2/3 in SELFDRIIVE mode. <b>Flashing with <math>\overline{CAL}</math>:</b> Probe error 1/2/3 during the calibration.
	Open door alarm. Only if the door remains open for a longer time than defined in parameter A12 (see page 27). Activates the alarm relay and the audible alarm.
	Maximum temperature in control probe alarm. The temperature value programmed in A1 has been reached (see page 26). Activates the alarm relay and the audible alarm.
	Minimum temperature in control probe alarm. The temperature value programmed in A2 has been reached (see page 26). Activates the alarm relay and the audible alarm.
	External alarm activated (by digital input) (see page 26). Activates the alarm relay and the audible alarm.
	Severe external alarm activated (by digital input) (see page 26). Activates the alarm relay and the audible alarm.
	Alarm for defrost completed due to time-out. The time set in d1 has been exceeded (see page 28).
	HACCP alarm. The temperature has reached the value of parameter h1 during a longer period than established in h2 (see page 27). Activates the alarm relay and the audible alarm.
	HACCP alarm due to a power supply failure. The temperature established in h1 has been reached, following a power supply failure (see page 27). Activates the alarm relay and the audible alarm.
	Indicates that a defrost is being performed (see page 20). Only displayed on screen.
	Password request. See parameters b10 and PAS (see page 28). Only displayed on screen.
	<b>Shown sequentially with the temperature:</b> The controller is in demo mode, the configuration has not been made.

## MESSAGES

 A digital display showing the text 'CAL' in white on a black background.

Calibration ongoing, therefore, avoid, as far as possible, opening the cold room during the process. For further information page 14.

 A digital display showing 'E16' in white on a black background. A small red triangle icon is visible at the bottom left.

**Flashing with temperature:** Configuration has been changed from 1 to 2 evaporators or vice versa.

## SELFDRIIVE MODE ALERT MESSAGES (Only shown pressing the ▼ key)

 A digital display showing 'E10/E20' in white on a black background. A diagonal slash is drawn over the text.

Defrost end error in 1/2 evaporator during the calibration, defrost has not ended due to temperature.

 A digital display showing 'E11/E21' in white on a black background. A diagonal slash is drawn over the text.

Error during calibration in 1/2 evaporator. There is not enough difference in temperature between the cold room probe and the evaporator probe.

 A digital display showing 'E12/E22' in white on a black background. A diagonal slash is drawn over the text.

It has not been possible to carry out the calibration due to a lack of stability in the system (Excessive door opening, excessive oscillations in the lower pressure, etc.).

 A digital display showing 'E13/E23' in white on a black background. A diagonal slash is drawn over the text.

Error during normal operation (SELFDRIIVE Mode active) in 1/2 evaporator. There is not enough difference in temperature between the cold room probe and the evaporator probe.

 A digital display showing 'E14/E24' in white on a black background. A diagonal slash is drawn over the text.

A lack of stability has been detected in the system (Excessive door opening, excessive oscillations in the low pressure, etc.) during normal operation (SELFDRIIVE Mode active).

 A digital display showing 'E15/E25' in white on a black background. A diagonal slash is drawn over the text.

The persistent lack of stability has led to the deactivation of the SELFDRIIVE mode.

 A digital display showing 'E17' in white on a black background. A small red triangle icon is visible at the bottom left.

Excessive door openings have been detected during calibration and it has not been possible to calibrate.

 A digital display showing 'E18' in white on a black background. A small red triangle icon is visible at the bottom left.

Excessive door openings have been detected and the device cannot regulate in SELFDRIIVE mode.

## SELFDRIIVE mode

SELFDRIIVE mode If the SELFDRIIVE mode is activated (default configuration), the device periodically evaluates the evaporator's heat transfer, managing the available resources to maximise it.

The defrosts are minimised, adapting to the changing conditions of the cold room, reducing heat input into the refrigerated space, thermal stress in the evaporator and energy consumption.

Operation of the evaporate fans is optimised taking into account the compressor status, evaporate temperature, frost level, opening of the door, etc.

The control function of the drainage resistor minimises its activation (moments before starting a defrost), thereby reducing energy consumption.

To achieve correct operation of the SELFDRIIVE mode, it is very important for the probes to be correctly installed, as described on page 8.



### Calibration

During the first hours of operation, the device performs two calibrations automatically, during which the display shows the **CAL** message.

Calibration may take several hours and include several refrigeration and defrost cycles.



#### IMPORTANT:

During the calibration processes, the following should be avoided:

- Opening the cold room door
- Turning the controller off or putting it on stand-by
- Changing controller parameters, including the set point



While the calibration process is active:

- Manual defrost cannot be activated (❄️ key)
- The continuous cycle cannot be activated
- The set point change function cannot be activated

If calibration cannot be performed, or if an important part of the installation is replaced (compressor, evaporator, etc.) it is advisable to perform a manual calibration.

It is also recommended (not essential) to perform a manual calibration, once the installation has completed its commissioning, with a load inside it and when its operating temperature has been stabilised, after several days of operation, in this way calibration is optimal.

In the event of changing the set point or hysteresis, the device performs a calibration again automatically, except if the set point change is made using the "set point change mode" function (see page 17).

To perform a manual calibration, access the parameter menu (see page 32) and follow the sequence indicated below:

- Access parameter **b30**
- A security code is requested, enter code 63
- Using keys ▲ and ▼, select option 1 and press **SET**.

**Cold regulation**

**Solenoid control (COOL Relay)**

Cold production is regulated by means of opening / closing the solenoid valve.

When the temperature in probe S1 reaches the set point (SP) value plus the probe's differential (C1), the solenoid opens and causes the temperature to drop. Once the set point (SP) value is reached, the solenoid closes.

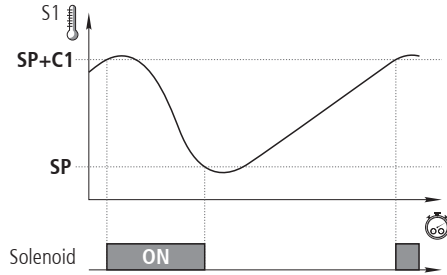

**Compressor control (Relay AUX 1)**

With Pump Down (Inl: 2, 5, 7)

**Requires the connection of a low pressure switch in digital input 1.**

When the temperature in probe S1 reaches the set point (SP) value plus the probe's differential (C1), the solenoid opens, causing the pressure in the evaporator to increase and, therefore, the low pressure switch deactivates and the compressor starts up.

Once the set point (SP) value is reached, the solenoid closes, causing the pressure in the evaporator to decrease, triggering the low pressure switch and stopping the compressor.

For further details of the process, see the next page.

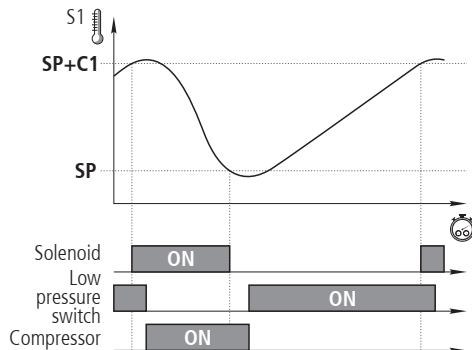

Without Pump Down (Inl: 3, 6, 8,)

The compressor operates simultaneously with the solenoid valve, starting up when the latter opens and stopping when it closes.

**Operation in the event of a fault in probe S1**

If probe S1 fails (fault, disconnection, etc. ), compressor behaviour will depend on parameter C6, with one of 3 options available:

**C6=0:** The compressor is stopped until probe S1 begins to operate again.

**C6=1:** The compressor is started-up until probe S1 begins to operate again

**C6=2:** The compressor operates in line with the average operation during the 24 hours prior to the error, taking into account the number of start-ups and stops and the average time in each state (stop-start). If 24 hours have not elapsed without a probe error, the device moves to **C6=3** mode.

**C6=3:** The compressor operates in line with the times programmed in C7 (ON) and C8 (OFF).

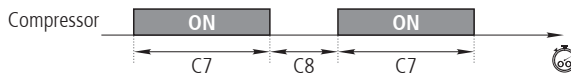

### Regulation of cold with two temperature probes (S1 + S3)

This requires configuration of digital input 2 as cold room temperature (**I20**=10).

The device regulates the temperature of the cold room taking into account the reading of both probes. Using parameter **C25**, the influence of probe S3 is determined in the regulation.

Examples:	<b>C25</b> =0	(S1: 100 % S3: 0 %)	<b>C25</b> =75	(S1: 25 % S3: 75 %)
	<b>C25</b> =60	(S1: 40 % S3: 60 %)	<b>C25</b> =95	(S1: 5 % S3: 95 %)

This mode is particularly useful in large volume cold room stores, where there may be significant variations of temperature.

In the event of an error in probe 3 (E3), the controller only uses the reading of probe 1. If both probes break (E1 + E3), the controller acts according to parameter **C6**.

### Continuous cycle mode

This is used to quickly cool the cold room stores before products are loaded and is activated by pressing the  key for 3 seconds.

Upon activating this mode, the compressor begins to operate until the temperature in probe S1 reaches the set point value, minus the variation indicated in parameter **C10**. The value of **C10** is always negative, unless it is 0. The unit will immediately return to normal operation. Should it not be possible to reach this point, the device will return to normal operation once the time configured in **C9** has elapsed, or by pressing the  key again for 5 seconds.

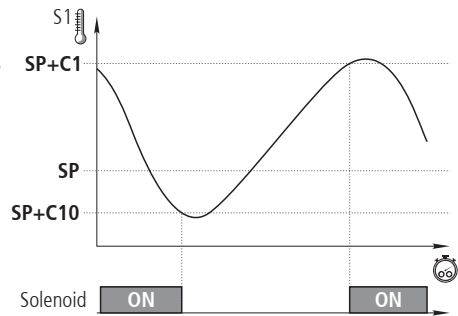

### Calibration of probe 1

Parameter **C0** allows for correction of the temperature detected by probe 1; this is particularly useful when the probe cannot be located in the ideal place.

### Set Point locking

Parameters **C2** and **C3** allow for an upper and lower limit to be established for the set point (**SP**), to protect the product or installation from Set Point manipulation.

### Product temperature

This function allows using a temperature probe to display the product temperature. To activate it, input 2 must be configured as "Product temperature" (**I20**=11), and the display of all the probes activated sequentially (**C21**=0).

**Set Point change mode**

This allows for quick alternation between two working temperatures in the cold room store, modifying the Set Point in line with the value indicated in parameter **C12**. The aforementioned value may be negative or positive, which allows for the Set Point to be reduced or increased. If it is configured in 0, the mode is disabled.

It is activated in three possible ways:

- By means of an external switch connected to one of the digital inputs. The digital input should be configured as "Set Point change (**I10** or **I20**=4). Activation through this method cancels any other activation and can only be deactivated using the same method.
- By means of the AKONet application. This requires the device to be connected to a Modbus network (see page 37).
- By means of the CAMM module and the AKO CAMM tool application.

**EXAMPLE:**

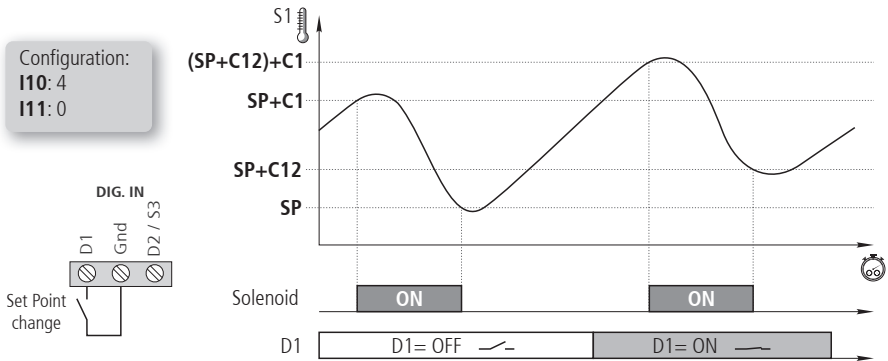

If the **SELFDRI**VE mode is active:

It is recommended for calibration to be performed with the lowest set point value.

It is recommended that the difference between set points is not greater than 5 °C in negative cold rooms and 2 °C in positive cold rooms.

**Compressor protection timing**

Parameter **C4** allows for selection of the type of timing to be applied to protect the compressor. These delays prevent continuous compressor starts and stops.

These timings affect the COOL and AUX 1 relays (if **o00**=1)

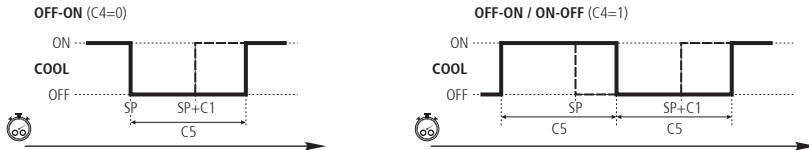

**OFF-ON** (C4=0): Minimum time in OFF mode before each start-up.

**OFF-ON / ON-OFF** (C4=1): Minimum time in ON and OFF mode for each cycle.

The delay time is defined by means of parameter **C5**; if **C5**=0, timing is disabled.

## Pump down function

This function foresees problems in the compressor caused by movements of coolant, using a stop/start technique for the installation, controlled via the liquid solenoid, the low pressure switch and the compressor itself.

This function is only available for In{ options 2, 5 and 7 and requires the connection of a low pressure switch in digital input 1. (I10=7)

### STOP

When the temperature in probe S1 reaches the set point (r) value, the COOL relay deactivates, closing the liquid solenoid.

Because the compressor continues to operate, pressure in the evaporator quickly drops. Upon reaching a given value, the low pressure switch activates, changing the status of digital input 1, which stops the compressor (relay AUX 1). This manoeuvre isolates all of the coolant in the high-pressure line, far from the compressor crankcase, preventing serious faults upon start-up.

Should the low pressure switch fail, the controller stops the compressor once the safety interval defined in C20 has elapsed, displaying the message "Pd" (an informative message that does not affect the unit's operation).

If C20 time is 0 (default value), the compressor will not stop until the low pressure switch is activated, but it will display the "Pd" message after 15 minutes.

### START

When the temperature in probe S1 reaches the set point value plus the differential (SP+C1), the COOL relay activates, opening the liquid solenoid. This increases the pressure in the evaporator, deactivating the low pressure switch, which turns the compressor on.

If, some time (determined by C19) after the liquid solenoid is opened (COOL relay set to ON), the low pressure switch does not deactivate, the controller will once again close the solenoid (COOL relay set to OFF) and the "LP" message will be displayed. This manoeuvre will be repeated every 2 minutes, indefinitely, until the pressure switch is deactivated and the installation reverts to its normal operation.

If C19 time is 0 (default value), the solenoid will remain open until the low pressure switch deactivates, but it will display the "LP" message after 5 minutes.



### STAND-BY

If the pump down function is active, a certain amount of time may elapse between starting the stand-by function and the controller stopping; this is because certain installation control phases cannot be interrupted.

To force the stop of the controller, press the Stand-by key again for 3 seconds.

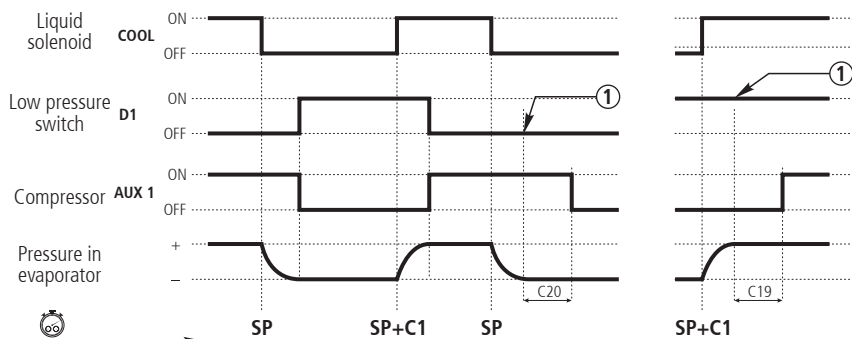

1: Pressure switch fault

### Door management

Door management requires configuring one of the digital inputs as "Door contact" (I10 ó r=1).

#### Standard operating mode (CE=0)

Door management allows for the installation's behaviour to be controlled, should the cold room door open through parameters C22 and C23.

Parameter C22 defines whether cold production should be stopped if the door opens. If C22=1, when the door opens, the fans stop and, 15 seconds later, the solenoid closes (COOL relay).

Parameter C23 defines the maximum time, in minutes, that the installation can remain without producing cold whilst the door is open. If C23=0, cold is not produced with the door open.

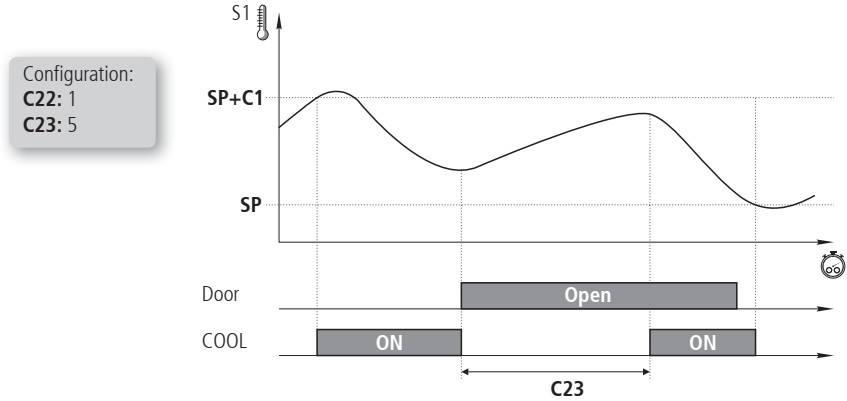

#### SELFDRIIVE operating mode (CE=1)

If the SELFDRIIVE mode is active, in the case of opening the door, the fans stop, or do not stop, depending on parameter C22. If the door does not close, when the time set in parameter C24 has passed, cold production stops and does not activate again until the time set in C23 has passed.

If, when the door is opened, cold is not being produced, only parameter C23 is taken into account.

#### Management of door frame resistor

If the Set Point is equal to or below -4°C and the relay AUX 2 has been configured as "door frame resistor" (o10=4), the resistor is activated (relay ON) when the temperature of the cold room drops below -3°C, and is deactivated (relay OFF) when 0°C is reached.

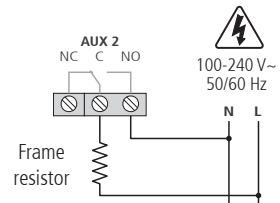

## Defrost

### Types of defrost

There are 3 possible defrost types, depending on the option selected in the wizard ( **fn f**):

#### Electric (Inl=1, 2 and 3) (d7=0)

Defrost is performed through electrical resistors, supplying the evaporator with heat. The operation of fans in this mode depends on parameter F3; the compressor and solenoid are stopped.

#### By air (Inl=4, 5 and 6) (d7=1)

Usually used in positive cold rooms (> 3°C), since the inside temperature of the cold room is sufficient to melt evaporator ice. By default, the fans are activated so that air may circulate through the evaporator; to stop them, change parameter F3 to 0. The compressor and solenoid are stopped.

#### Hot gas (Inl=7 and 8) (d7=2)

The hot gas from compressor discharge is used to melt evaporator ice and, to this end, two valves are necessary: one at the condenser input (A) (SSV relay) and another between the compressor output and the evaporator input (B) (DEF relay).

During the process, the liquid solenoid valve (C) and the condenser input valve are closed and the evaporator input valve is opened, forcing hot gas to pass through the latter and melting the ice.

Optionally, a high pressure switch (D) can be added to control the solenoid valve (digital input D2, I20=9) during the defrost process using hot gas. If the pressure decreases, the solenoid opens to allow liquid into the tank; when the pressure rises again, the solenoid closes.

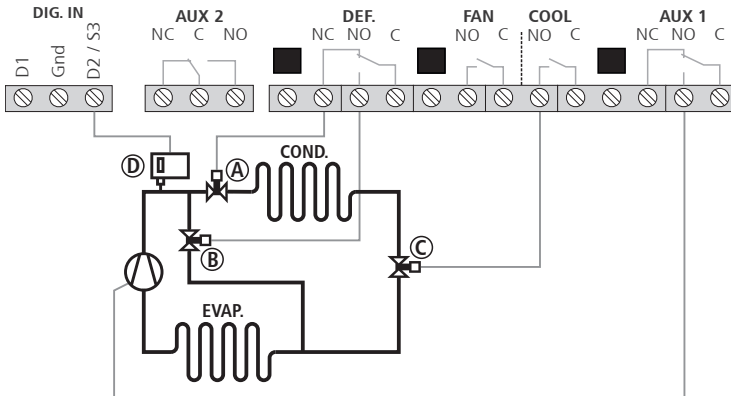

### Control of defrost in standard mode (CE=0)

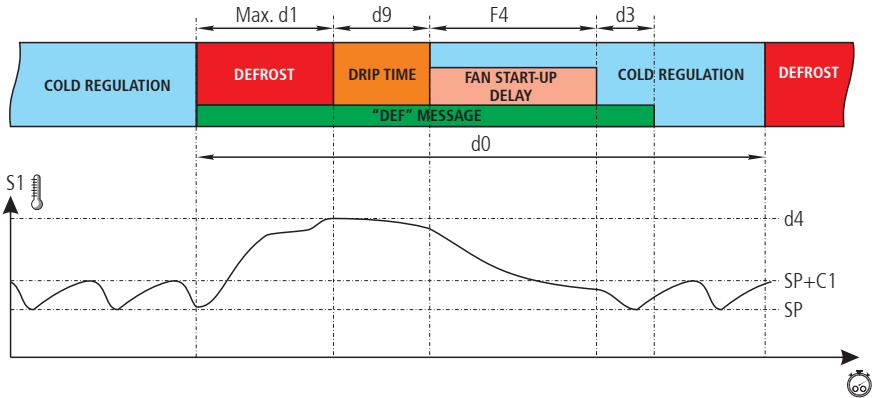

#### Defrost start

Defrost will start if:

- The time programmed in parameter **d0** has elapsed since the start of the last defrost.
- We press the **⌘** key for 3 seconds.
- By means of an external push-button (**I10 / I11=5**).
- Through the app or through AKONet.

#### Defrost completion

Defrost will complete if:

- The temperature programmed in parameter **d4** has been reached in probe 2. This requires a 2nd probe (**I00=2**) to be available, located in the evaporator.
- The time configured in parameter **d1** has elapsed (maximum defrost duration).
- We press the **⌘** key for 5 seconds.
- By means of an external push-button (**I10 / I11=5**).
- Through the app or through AKONet.

**Control of defrost in SELFDRIIVE mode (CE=1)**

Defrosts in SELFDRIIVE mode are not programmed, but rather the device evaluates the operation of the cold room and manages defrosts depending on the needs of the installation.

If a drop in the performance of the cold room is detected due to formation of ice in the evaporator, defrost is activated and it is supervised until its completion.

Using parameter **d30**, the defrost strategy is defined, a lower value allows less formation of frost in the evaporator, while a higher value acts with lower frequency allowing more frost to accumulate in the evaporator.

As a rule, a more aggressive strategy provides the system with greater efficiency allowing more frost to accumulate.

Adapting the value of this parameter to the type of evaporator used and to the type of defrost configured according to the following table is recommended:

		TYPE OF DEFROST								
		ELECTRIC			AIR			HOT GAS		
Fin spacing of the evaporator in mm	< 3	0	1	2	1	3	4	0	1	2
	3.5	0	1	2	1	3	4	0	1	2
	4	1	2	3	2	4	5	0	1	2
	4.5	2	3	4	3	5	6	1	2	3
	5	2	3	5	3	5	7	1	2	3
	5.5	2	3	5	3	5	7	1	2	4
	6	3	4	6	4	6	8	1	3	4
	6.5	3	4	6	4	6	8	1	3	4
	7	4	5	7	5	7	9	2	3	4
	7.5	4	6	7	5	8	9	2	3	4
	8	4	6	8	5	8	10	3	4	5
	8.5	5	7	8	6	9	10	3	4	5
	9	5	7	8	6	9	10	4	5	6
	9.5	5	9	8	6	10	10	4	5	6
10	6	8	9	7	10	10	4	5	6	
10.5	6	8	10	7	10	10	4	5	6	
≥ 11	6	9	10	7	10	10	4	5	6	

Strategy: Conservative Moderate Aggressive

Parameter **d31** allows establishing a time limit without making defrosts, if the cold room does not require defrosts set it to 0, if the cold room can generate frost it is recommended to set a security time of between 2 and 7 days.

Parameter **d32** defines the maximum time permitted of the cold room without reaching the Set Point, after which an emergency defrost starts to unlock the evaporator.

Parameter **d4** defines the final defrost temperature.



It is advisable to configure all the parameters relating to defrost since, in the event of a calibration or operating error of the SELFDRIIVE mode, the controller then temporarily regulates in standard mode.

## Other defrost parameters (They affect in standard and SELFDRIVE mode)

### Drip time

This is established through parameter **d9** and sets the time added at the end of defrost to allow for the removal of surplus water from melted evaporator ice, during which there is no cold regulation.

### Fan start-up delay

This is established through parameter **F4** and allows for the possible drops left in the evaporator to freeze before the fans activate, preventing them from being projected into the cold room. It also prevents heat being supplied to the cold room due to defrost in the evaporator.



If defrost is cancelled before 1 minute has elapsed, the drip time (**d9**) is not applied and the fans are activated without taking into account the start-up delay (**F4**).

If defrost is by air or is static, the drip time (**d9**) and fan start-up delay (**F4**) are deactivated.

### Message displayed during defrost

This is established using parameter **d2**, and you can choose between displaying the real temperature captured by probe 1 (**d2=0**), showing the temperature captured by probe 1 at the start of the defrost (**d2=1**), or displaying the dEF (**d2=2**) message. Parameter **d3** defines the time during which the aforementioned message will be displayed once the drip time (**d9**) and fan stop time (**F4**) are complete.

### Remote defrost

This function allows defrost of the unit to be activated using an external button, connecting it to one of the digital inputs that must be configured as remote defrost (**I10** or **I20=5**).

### Defrost locking

This prevents defrost starting at unusual points by means of an external switch, which may be useful for ensuring that the installation's load does not excessively increase, exceeding the permitted limits.

The external switch must be connected to one of the digital inputs, which should be configured as "Defrost locking" (**I10** or **I20=6**).

### Miscellaneous

Using parameter **d5**, you can configure whether the unit performs a defrost (**d5=1**) or not (**d5=0**) when it receives power (first start-up or after a power supply failure). Should the option YES (**d5=1**) be selected, defrost will begin once the delay time defined in **d6** has elapsed.

Using parameter **d8**, we define the time tally established in **d0**, choosing between total time elapsed (**d8=0**) or the sum of compressor operation time (**d8=1**).



**REMARK:** If parameter **d1** is configured to 0, no defrosts are performed.

### Management of the drainage resistor

Activates the drainage resistor before the start of defrost and deactivates it one hour after finishing, avoiding unnecessary energy consumption in the absence of defrosts.

For this function to be active, parameter **o10** (Relay AUX 2) should be set to 8.

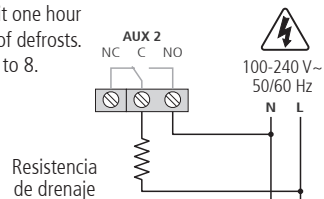

### Defrost of a second evaporator

This function allows for defrost to be controlled in a second evaporator, provided that defrost is by electric heat, by air or is static. The same type of defrost should be used for the first and second evaporators.

This requires configuration of input 2 as a 2nd evaporator probe (**i20=8**). In the event of an error in the 2nd evaporator probe, defrost completes once the time defined in **d1** has elapsed.

#### Electric defrosting

This requires configuration of relay AUX 2 as 2nd evaporator defrost (**o10=5**).

Defrost begins simultaneously in both evaporators. When the probe of evaporator 1 reaches the temperature defined in **d4**, the DEF relay deactivates, completing defrost of evaporator 1. Defrost of evaporator 2 is completed when the evaporator 2 probe reaches the temperature defined in **d4**. Drip time begins when both defrosts are complete.

#### Defrost by air

The fans of both evaporators are connected in parallel to the FAN relay.

Defrost begins simultaneously in both evaporators and does not complete until both probes reach the temperature defined in **d4**. Drip time subsequently begins.

## Evaporator fans

### Control of fans in standard mode (CE=0)

Fans are controlled through probe 2 (evaporator) and parameters **F0** (stop temperature) and **F1** (probe differential). If probe 2 is not connected or an error in the probe (**E2**) is detected, the fans continuously operate without taking into account parameters **F0** and **F1**, but taking the remaining parameters (**F2** to **F4**) into account.

Using parameter **F2**, the status of the fans during compressor stops is defined.

Using parameter **F3**, the status of the fans during defrost is defined.

Parameter **F4** defines the fan start-up delay time after defrost (see page 21).

Parameter **C22** defines whether fans stop when the door is opened.

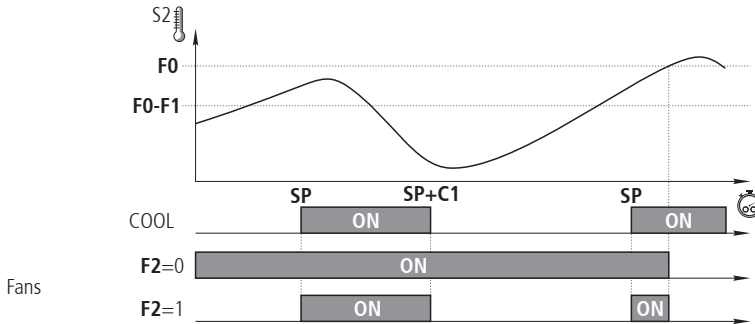

### Control of fans in SELFDRIIVE mode (CE=1)

With the SELFDRIIVE mode active, fan control is performed taking into account the evaporator temperature, compressor, frost level, the cold room temperature and if the door is open or not, optimising its operation. In this way its operation is optimised to obtain the greatest energy efficiency of the cold room. With this mode active, only parameters **F0**, **F1** and **F4** need to be configured.



It is advisable to configure all parameters relating to the fans since, in the event of a calibration or operating error of the SELFDRIIVE mode, the controller then temporarily regulates in standard mode.

## Alarms

The device warns the user through an on-screen message, activation of a relay (only if **o10=1**) and a sound alarm when the criteria programmed in the parameters are met.

### Maximum / minimum temperature alarm

It shows the message "**RH**" or "**RL**" when the temperature in probe 1 reaches the value configured in parameters **A1** (maximum temperature) and **A2** (minimum temperature).



This value may be:

Absolute (**A0=1**): The temperature at which the alarm should activate must be indicated in **A1/A2**.

Relative to the **SP (A0=0)**: The increase or decrease in the number of degrees necessary for the alarm to activate, in relation to the set point, must be indicated in **A1/A2**. This option enables us to change the set point without having to reset the maximum and minimum alarms.

Parameter **A10** establishes the differential of both parameters (Hysteresis).



#### Example

We configure the following parameters in a controller: **SP=2**, **A1=10**, **A10=2**

-If **A0=0** (Relative to the SP), the maximum temperature alarm will activate when 12 degrees are reached in probe 1, and will deactivate when 10 degrees are reached.

-If **A0=1** (Absolute), the maximum temperature alarm will activate when 10 degrees are reached in probe 1, and will deactivate when 8 degrees are reached.

### External alarm / severe external alarm

The message **ER** (External alarm) or **SER** (Severe external alarm) is displayed when the digital input configured as external alarm or severe external alarm is activated.



The severe external alarm also deactivates all the loads and, therefore, temperature regulation stops. When this alarm disappears, the device returns to its normal operation.

At least one of the digital inputs must be configured as an external alarm (**I10** or **I20=2**) or as a severe external alarm (**I10** or **I20=3**).

### Probe error alarm

If one of the enabled probes is crossed, in open circuit or out of range, the message **E1**, **E2** or **E3** will be shown, depending on whether probe S1, S2 or S3 is involved.



### Evaporator probe error alarm due to moisture ingress

If, at the start of defrost, the temperature in probe S2 is 20°C higher than the temperature in probe S1, the defrost ignores probe S2 and completes due to time-out.



The display shows the message **E2**, activates the alarm relay (only devices with 5 relays and if **o10=1**) and sound alarm.

The alarm can be silenced, but the  alarm icon will not disappear until:

The controller is switched off and then on again.

Defrost without error is started in probe S2.

If the 2nd evaporator probe (**I20=8**) has been enabled, it will behave in the same way, but displaying the message **E3**.

### Open door alarm

The door has been open for a longer time than defined in parameter **A12**, the open door alarm is activated.

In order to detect the open door, configuration is required of one of the digital inputs as "door contact" (**I10** or **I20**=1).

Activates alarm relay (only if **o10**=1) and sound alarm.



### HACCP alarm

The alarm is activated should situations be detected which could endanger the integrity of the products stored in the cold room.

If the temperature of the cold room is higher than that defined in parameter **h1** for a length of time exceeding that defined in parameter **h2**, the alarm activates, displaying the message **hCP** on screen.

Upon pressing the mute key, the sound alarm switches off, but the alarm remains.

Once the temperature drops below parameter **h1**, if the mute key has been pressed, the alarm disappears. If the mute key has not been pressed, the audible alarm deactivates but the HACCP indicator remains in flashing mode, indicating that a non-confirmed HACCP alarm has occurred.

Press the mute key to confirm an HACCP alarm.

If, during a power failure, a HACCP alarm occurs, when the power supply returns, the HACCP alarm is activated and the display shows the messages **hCP** and **PF** (power failure) alternately.



### Alarm delays

These delays prevent certain alarms from being shown, to allow the installation to recover its normal operation after certain events.

- Delays in start-up (A3): This delays the activation of the temperature alarms upon receiving power (at start-up or after a power supply failure) or when exiting Stand-by mode. This allows for the installation to start up avoiding alarms.
- Delay after a defrost (A4): This delays the activation of the temperature alarms when a defrost completes.
- Delay to minimum and maximum temperature alarm (A5): This delays the activation of the maximum (A1) and minimum (A2) temperature alarms, from when the temperature in probe 1 reaches the programmed value.
- Delay to activation of external alarm (A6): This delays the activation of the external alarm, from when the digital input becomes active.
- Delay to deactivation of external alarm (A7): This delays the deactivation of the external alarm, from when the digital input becomes active.
- Delay to open door alarm (A12): This delays the activation of the alarm upon detecting that the door is open.

### Configuration of alarm relay (only devices with 5 relays)

Should relay AUX 2 have been configured as an alarm (**o10**=1), parameter **A9** allows for the relay status to be defined when an alarm is triggered:

- **A9**=0 Relay active (ON) in the event of an alarm (OFF without alarm)
- **A9**=1 Relay inactive (OFF) in the event of an alarm (ON without alarm)

## Alerts

The device alerts the user through an on-screen message when an event occurs which requires his/her attention. However, it does not activate the sound alarm or the alarm relay (if active).

### Defrost finished by time alarm

The message **AdE** is displayed when a defrost has completed due to time-out, if parameter A8=1.



### Pump down malfunction error (stop)

The message **Pd** is displayed if a malfunction is detected when the installation is stopped using the pump down manoeuvre. (see page 18).



### Pump down malfunction error (start-up)

Displays the **LP** message if a malfunction is detected when the installation is started up using the pump down manoeuvre. (see page 18).



## Light control

Relay AUX 1 or AUX 2 must be configured as "Light" (o00 or o10=2).

Switching the lights on or off is controlled using:

The  push-button: One press switches the lights on or off.

The cold room door: When the door is opened, the lights remain on for the time defined by parameter **b01**. If the value is 0, when the door closes the lights go out. (One of the digital inputs must be configured as door contact (I10 or I20=1).

The control even occurs with the equipment in Stand-by.

## Password

It allows protecting the configuration of the unit using a 2 digit code (from 01 to 99). If it is active a code is requested when you try to access the programming menu. This menu cannot be accessed if a wrong value is entered. The code is set via the **PAS** parameter.

Parameter **b10** defines the operation of this code.



## Remote Stand-by mode

This allows activating Stand-by mode using a switch connected to one of the digital inputs.

Said digital input must be set to Stand-by remote activation (I10=8 or I20=12).

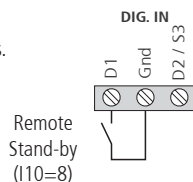

## Operation of the auxiliary relays

Depending on the controller model, it may have 1 or 2 auxiliary relays. The function of these relays is configurable through the parameters menu.

### AUX 1 relay

- **Deactivated (o00=0):** It does not carry out any function.
- **Compressors / crankcase resistor (o00=1):** Controls compressor operation. When the compressor is not in operation, it powers the crankcase resistor. This function can only be selected via the initial wizard ( *ini* ).
- **Light (o00=2):** This regulates the operation of cold room light (see page 28).
- **Virtual control (o00=3):** The relay can be remotely activated and deactivated by means of AKONet software.

### AUX 2 relay

- **Deactivated (o10=0):** It does not carry out any function.
- **Alarm (o10=1):** This activates the relay every time that an alarm occurs (see page 26).
- **Light (o10=2):** This regulates the operation of cold room light (see page 28).
- **Virtual control (o10=3):** The relay can be remotely activated and deactivated by means of AKONet software.
- **Door frame resistor (o10=4):** This controls the operation of the cold room's door frame resistor (see page 19).
- **Defrost 2° evaporator (o10=5):** This controls the defrost resistors of a second evaporator (see page 24).
- **Same as solenoid status (o10=6):** Imitates solenoid status: active if the solenoid is in ON mode, inactive if the solenoid is in OFF mode.
- **Same as unit status (o10=7):** Indicates the unit's status: active if the unit is in ON mode, inactive if the unit is in Stand-by mode.
- **Drainage resistor (o10=8):** Controls the activation/deactivation of the evaporator drainage resistor (see page 23).

**Core Index** (Only with CAMM module installed)

The Core index is an indicator of the integral efficiency of the cold room store that can be consulted in the AKO CAMM Tool app, available in the App Store and in Google Play.

Provides weighted information on:

- **Effectiveness of the cold:** Percentage of time that the cold room is in the configured operating range (between SP and SP+C1).
- **Energy efficiency:** Percentage of the operating time of the main system loads (compressor, defrost, etc.) compared to the value considered as reasonable.
- **Maintenance rate:** Number of activations by hour of the compressor and the defrost, compared to the value considered as reasonable.

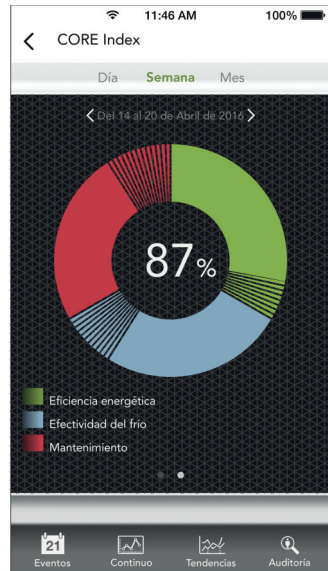
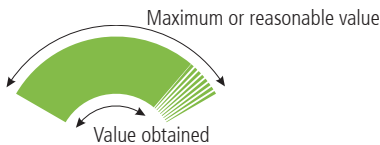

**Dashboard**

The Dashboard provides general operating indicators of the device to facilitate analysing its operation. The indicators can be displayed in three ways, daily, weekly or monthly summary.

**Average temperature:** Indicates average temperature of the cold room

**Time in set point:** Indicates percentage of time the cold room has been between SP and SP+C1.

**Time ON:** Indicates percentage of time the cold room has been operating.

**Cooling time:** Indicates percentage of activation time for the cold solenoid valve.

**HACCP Alarms:** Indicates number of HACCP alarms registered.

**Alarms:** Indicates number of alarms registered.

**Door open time:** Indicates percentage of time with the cold room door open.

**Defrost time:** Indicates percentage of time with defrost activated.



\* Not available in AKO-16525AN

# Configuration

## Condensed programming menu

This allows for the most-used parameters to be quickly configured. Press the **SET** key for 3 seconds to access it.

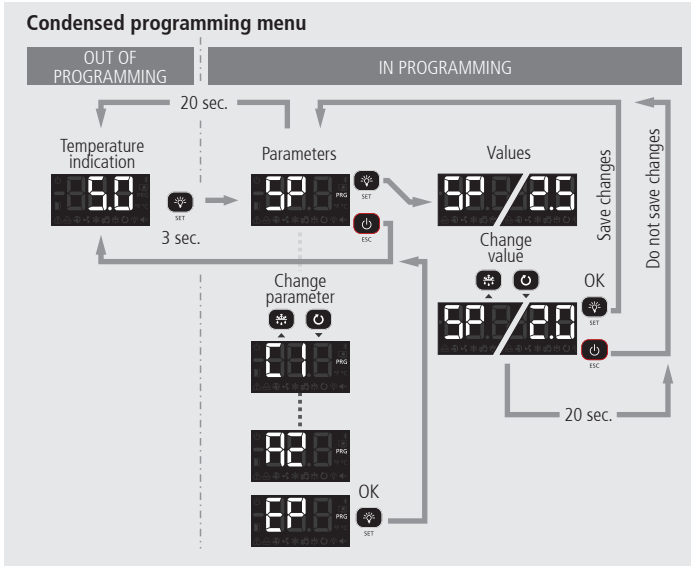

## Parameters

Level 2

	Description	Values	Min.	Def.	Max.
SP	Temperature setting (Set Point)	°C/°F	-50	0.0	99
EE	SELFDRIIVE Mode 0=Deactivated 1= Activated		0	1	1
E1	Probe 1 differential (Hysteresis)	°C/°F	0.1	2.0	20.0
d0	Defrost frequency (Time between 2 starts)		0	6	96
d1	Maximum defrost duration (0=defrost deactivated)		0	*	255
d4	Final defrost temperature (by probe) (If P4 ≠ 1)	°C/°F	-50	8.0	50
F3	Status of the fans during the defrost 0=Shut down; 1=Running		0	0	1
R1	Alarm for maximum in probe 1 (It should be higher than the SP)	°C/°F	A2	99	99
R2	Alarm for minimum in probe 1 (It should be lower than the SP)	°C/°F	-50	-50	A1
d30	Defrost strategy in SELFDRIIVE mode		0	5	10

\* According to wizard.

### Extended programming menu

Use the extended programming menu to configure all of the unit's parameters in order to adapt it to your installation requirements. Press the SET key for 6 seconds to access it.



**IMPORTANT:** If the password function has been configured as a keypad lock (**b10=2**), or as an access to parameters block (**b10=1**), you will be requested to enter the password programmed in **PAS** when attempting to access either of the two functions. If the entered password is not correct, the unit will go back to showing the temperature.

**IMPORTANT:** Certain parameters or menus may not be visible depending on the configuration of the rest of the parameters.

### Extended programming menu

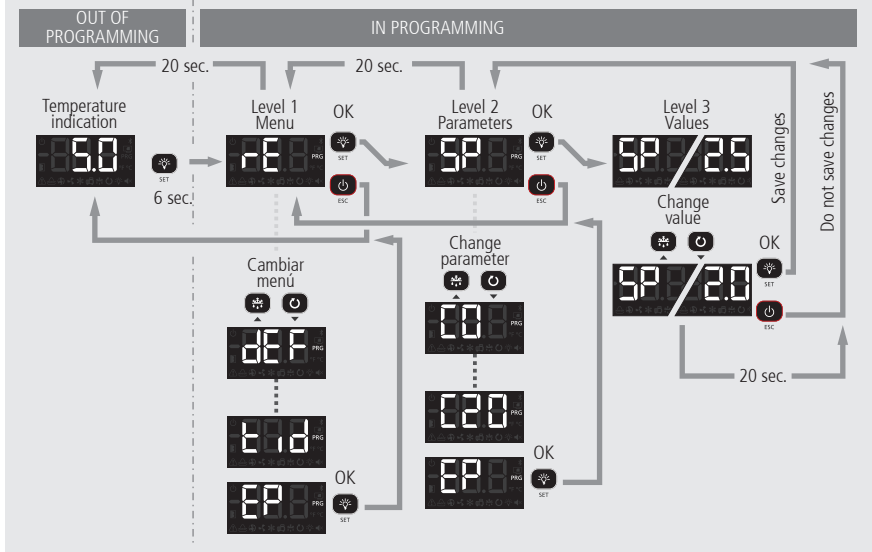

## Parameters

Level 1	Level 2	Regulation and control	Description	Values	Min.	Def.	Max.
P	SP		Temperature setting (Set Point)	°C/°F	-50	0.0	99
	CE		SELFDRIIVE Mode 0=Deactivated 1= Activated		0	1	1
	C0		Probes 1 & 2 calibration (Offset)	°C/°F	-4.0	0.0	4.0
	C1		Diferencial de la sonda 1 (Histéresis)	°C/°F	0.1	2.0	20.0
	C2		Set Point top locking (it cannot be set above this value)	°C/°F	C3	99	99
	C3		Set Point bottom locking (it cannot be set below this value)	°C/°F	-50	-50	C2
	C4		Type of delay for the protection of the compressor: 0=Minimum time of compressor in OFF 1=Minimum time of compressor in OFF and in ON in each cycle		0	0	1
	C5		Protection delay time (Value of the option selected in parameter C4)	Min.	0	0	120
	C6		COOL relay status with fault in probe 1: 0=OFF; 1=ON; 2=Average according to last 24h prior to probe error 3=ON-OFF according to prog. C7 and C8		0	2	3
	C7		Relay time in ON in the event of probe 1 failure (If C7=0 and C8≠0, the relay will always be disconnected in OFF)	Min.	0	10	120
	C8		Relay time in OFF in the event of probe 1 failure (If C8=0 and C7≠0, the relay will always be connected in ON)	Min.	0	5	120
	C9		Maximum duration of the continuous cycle mode. (0=deactivated)	h.	0	0	48
	C10		Variation of the Set Point (SP) in continuous cycle mode. When it reaches this point (SP+C10), it reverts to the normal mode. (SP+C10 ≥ C3). The value of this parameter is always negative, unless it is 0. (0=OFF)	°C/°F	0	-50	C3-SP
	C12		Variation of the Set Point (SP) when the change Set Point function is active. (SP+C12 ≤ C2) (0= deactivated)	°C/°F	C3-SP	0.0	C2-SP
	C19		Maximum start time from Pump Down (Values between 1 and 9 seconds will not be accepted) (0=deactivated)	Sec.	0	0	120
	C20		Maximum time for pump down (0= deactivated)	Min.	0	0	15
	C21		Probe to be displayed 0=All probes (sequential) 1=Probe 1 (Chamber) 2=Probe 2 (Evaporator) 3=Probe 3 (According to I20) 4=Weighted temperature of the cold room		0	1	3
	C22		Stop fans and compressor on opening door 0=No 1=Yes		0	0	1
	C23		Start-up delay for fans and compressor with door open	Min.	0	0	999
	C24		Delay time of cold stop with door open.	Sec.	0	0	C23
	C25		Influence of probe S3 when regulating with two temperature probes (I20=10) (see page 16)	%	0	0	95
	C27		Probe 3 calibration (Offset)	°C/°F	-4.0	0.0	4.0
	EP		Exit to level 1				

Level 1	Level 2	Description	Values	Min.	Def.	Max.
dEF	d0	Defrost frequency (Time between 2 starts)	h.	0	6	96
	d1	Maximum defrost duration (0=defrost deactivated)	Min.	0	*	255
	d2	Type of message during the defrost: 0=Displays the real temperature; 1=Displays the temperature at the start of the defrost; 2=Displays the dEF message		0	2	2
	d3	Maximum duration of the message (Time added at the end of the defrost process)	Min.	0	5	255
	d4	Final defrost temperature (by probe) (If I00 ≠ 1)	°C/°F	-50	8.0	50
	d5	Defrost on connecting the unit: 0=NO First defrost according to d0; 1=YES, First defrost according to d6		0	0	1
	d6	Delay of the defrost start on connecting the unit	Min.	0	0	255
	→ d7	Type of defrost: 0=Resistors; 1=Air/fans 2=Hot gas; 3=Reversal of cycle		0	*	3
	d8	Count of time between defrost periods: 0=Total real time 1=Sum of compressor connected time		0	0	1
	d9	Drip time when completing defrost (Shutdown of compressor and fans)	Min.	0	1	255
	d30	Defrost strategy in SELFDRIVE mode (see page 22)		0	5	10
	d31	Maximum time without defrosting (0=Deactivated)	h.	0	96	999
	d32	Maximum time of cold room outside the temperature regulation range (0=Deactivated)	h.	0	2	10
	EP	Exit to level 1				

Level 1	Level 2	Description	Values	Min.	Def.	Max.
dEF	F0	Shutdown temperature of fans	°C/°F	-50	45	50
	F1	Probe 2 differential if fans are shut down	°C/°F	0.1	2.0	20.0
	F2	Shut down fans when the compressor shuts down 0=No 1=Yes		0	0	1
	F3	Status of the fans during the defrost 0=Shut down; 1=Running		0	0	1
	F4	Delay of start-up after defrost (If F3=0) It will only actuate if it is higher than d9	Min.	0	2	99
	EP	Exit to level 1				

\* According to wizard.

→ It can only be modified using the configuration wizard (Inl).

Level 1	Level 2	Alarms		Description	Values	Min.	Def.	Max.
RL	R0			Configuration of the temperature alarms 0=Relative to SP 1=Absolute		0	1	1
	R1			Alarm for maximum in probe 1 (It should be higher than the SP)	°C/°F	A2	99	99
	R2			Alarm for minimum in probe 1 (It should be lower than the SP)	°C/°F	-50	-50	A1
	R3			Delay of temperature alarms in the start-up	Min.	0	0	120
	R4			Delay of temperature alarms from the end of a defrost	Min.	0	0	99
	R5			Delay of temperature alarms from when the A1 or A2 value is reached		0	30	99
	R6			Delay of the external alarm/Severe external alarm on receiving a signal in digital input (I10 or I20 =2 or 3)	Min.	0	0	120
	R7			Delay of external alarm deactivation/Severe external alarm deactivation when the signal in digital input disappears (I10 or I20=2 or 3)	Min.	0	0	120
	R8			Show warning if the defrost ends for maximum time 0=No 1=Yes		0	0	1
	R9			Relay alarm polarity 0= Relay ON in alarm (OFF without alarm); 1= Relay OFF in alarm (ON without alarm)		0	0	1
	R10			Diferencial de alarmas de temperatura (A1 y A2)	°C/°F	0.1	1.0	20.0
	R12			Delay of open door alarm (If I10 or I20=1)	Min.	0	10	120
	EP			Exit to level 1				

Level 1	Level 2	Basic configuration		Description	Values	Min.	Def.	Max.
bcn	b00			Delay of all functions on receiving power supply	Min.	0	0	255
	b01			Cold room light timing	Min.	0	0	999
	b10			Function of password 0=Inactive 1=Block access to parameters 2=Block keypad		0	0	2
	PR5			Access code (Password)		0	0	99
	b20			MODBUS address		1	1	247
	b21			Communication speed: 0=9600 bps 1=19200 bps 2=38400 bps 3=57600 bps	bps	0	0	3
	b22			Acoustic alarm enabled 0= No 1=Yes		0	1	1
	b30			Activation of manual calibration 0=Deactivated 1= Activated Requires security code, see page 14		0	0	1
	UnE			Work units 0=°C 1=°F		0	0	1
	EP			Exit to level 1				

\* According to wizard.

Level 1	Level 2	Inputs and outputs				
		Description	Values	Min.	Def.	Max.
In	i00	Connected probes 1=Probe 1 (Cold room) 2=Probe 1 (Cold room) + Probe 2 (Evaporator)		1	2	2
	i10	Configuration of digital input 1 0= Deactivated 1=Door contact 2=External alarm 3=Severe external alarm 4=Change of SP 5=Remote defrost 6=Defrost block 7= Low pressure switch 8=Remote Stand-by		0	*	8
→	i11	Polarity of the digital input 1 0=Activates on closing contact; 1=Activates on opening contact		0	*	1
	i20	Configuration of digital input 2 0= Deactivated 1=Door contact 2=External alarm 3=Severe external alarm 4=Change of SP 5=Remote defrost 6=Defrost block 7=Register probe 8=Probe 2° evaporator ** 9=High pressure switch for Hot Gas 10=2nd cold room temperature probe 11=Product temperature 12=Remote Stand-by		0	0	12
→	i21	Polarity of the digital input 2 0=Activates on closing contact; 1=Activates on opening contact		0	0	1
	o00	Configuration of relay AUX1 0=Deactivated 1=Compressor/Resistor sump 2=Light 3=Virtual control		0	*	3
→	o10	Configuration of relay AUX2 0=Deactivated 1=Alarm 2=Light 3=Virtual control 4=Door frame resistance 5=Defrost 2° evaporator 6=Same as solenoid status 7=Same as unit status 8=Drainage resistor		0	2	8
	EP	Exit to level 1				

Level 1	Level 2	HACCP alarm				
		Description	Values	Min.	Def.	Max.
HCP	h1	Maximum temperature of HACCP alarm	°C/°F	-50	99	99
	h2	Maximum permitted time for activation of the HACCP alarm (0=Disabled)	h.	0	0	255
EP		Exit to level 1				

Level 1	Level 2	Information (Reading only)				
		Description	Values	Min.	Def.	Max.
HCP	in1	Option chosen in the configuration wizard				
	Pd	Pump down active? 0=No 1=Yes				
→	PV	Programme version				
	Pr	Programme revision				
	bV	Bootloader version				
	br	Bootloader revision				
	PRr	Parameter map revision				
EP		Exit to level 1				

\* According to wizard.

→ It can only be modified using the configuration wizard (InI).

## Connectivity

The controllers are equipped with a port for connection of RS485 (MODBUS) data, which allows for remote management of these using a AKO-5010, AKO-5025, AKO-5041 or AKO-5051 gateway.

The MODBUS address is factory-set and is indicated on the rating plate located on the left side of the controller. This address must be different for each unit within the same network. The address can be changed using parameter **b20**. Once modified, the old address indicated on the plate will not be valid.

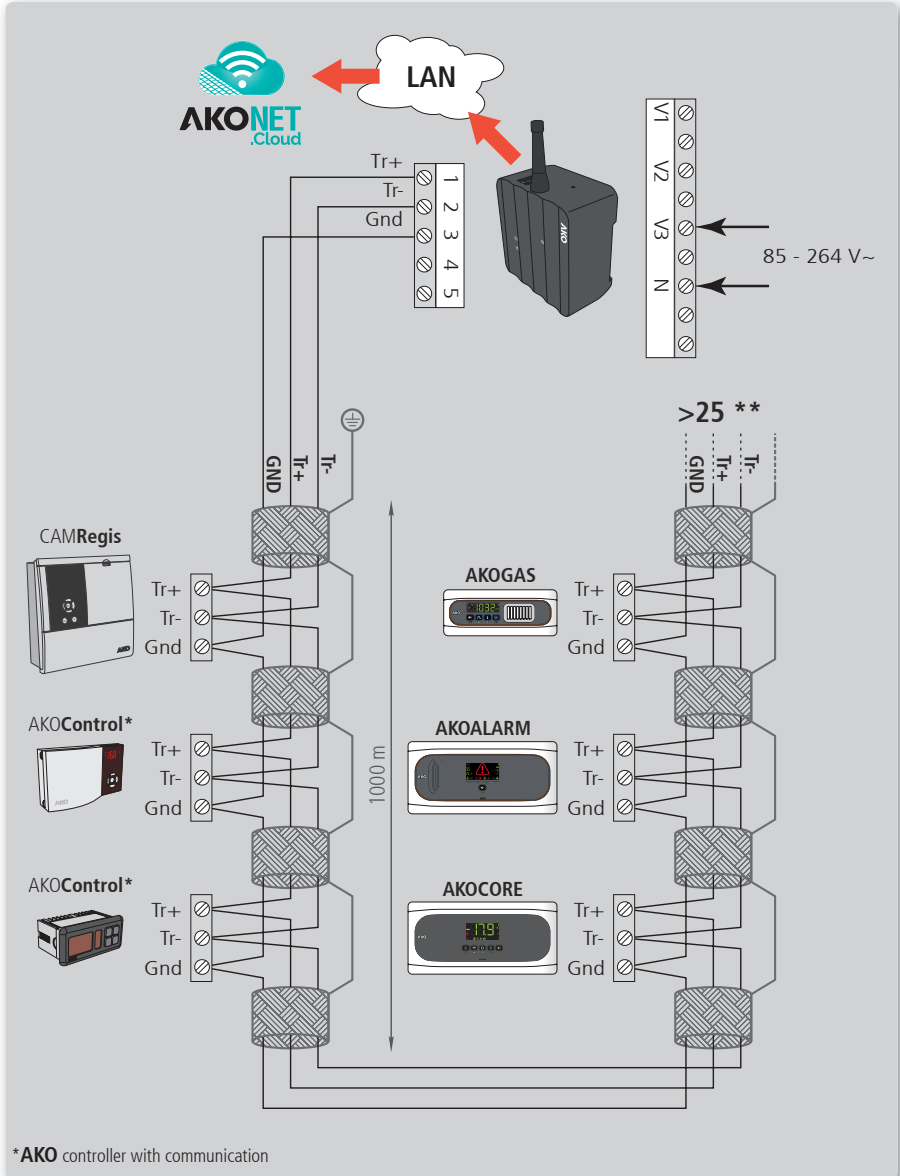

## Technical specifications

Power supply.....	100 - 240 V~ 50/60 Hz
Maximum input power in the operation .....	6.3 VA
Maximum nominal current.....	15 A
Relay AUX 2 - SPDT - 16 A	NO ..... (EN60730-1: 12 (9) A 250 V~)
	NC ..... (EN60730-1: 10 (8) A 250 V~)
Relay DEF - SPDT - 20 A	NO ..... (EN60730-1: 15 (15) A 250 V~)
	NC ..... (EN60730-1: 15 (13) A 250 V~)
Relay COOL - SPST - 16 A.....	(EN60730-1: 12 (9) A 250 V~)
Relay FAN - SPST - 16 A.....	(EN60730-1: 12 (9) A 250 V~)
Relay AUX 1 - SPDT - 20 A	NO ..... (EN60730-1: 15 (15) A 250 V~)
	NC ..... (EN60730-1: 15 (13) A 250 V~)
No. of relay operations .....	EN60730-1:100.000 operations
Probe temperature range.....	-50.0 °C to 99.9 °C
Resolution, setting and differential.....	0.1 °C
Thermometric precision.....	±1 °C
Loading tolerance of the NTC probe at 25 °C.....	±0.4 °C
Input for NTC probe .....	AKO-14901
Working ambient temperature.....	-10 °C to 50 °C
Storage ambient temperature .....	-30 °C to 60 °C
Protection degree.....	IP 65
Installation category.....	II s/ EN 60730-1
Pollution degree.....	II s/ EN 60730-1
Control device classification: Built-in assembly, with Type 1.B automatic operation action feature, for use in clean situations, logical support (Software) class A and continuous operation. Degree of contamination 2 acc. to UNE-EN 60730-1.	
Double isolation between power supply, secondary circuit and relay output.	
Temperature during ball-pressure test	Accessible parts ..... 75 °C
	Parts which position active elements..... 125 °C
Current of radio jamming supression tests .....	270 mA
Voltage and current as per EMC tests: .....	207 V, 17 mA
Type of assembly.....	Fixed internal
MODBUS address.....	Shown on label
Dimensions .....	290 mm (W) x 141 mm (H) x 84.4 mm (D)
Internal buzzer	

### AKO-16525AN

Maximum transmission power .....	23.5 dBm conducted
Antenna.....	Internal
Bands .....	NB IoT (Narrow band) LTE Cat NB1   B2, B3, B4, B8, B12, B13, B20

Band	Rx Frequency	Tx Frequency
2 .....	1930 MHz ~ 1990 MHz .....	1850 MHz ~ 1910 MHz
3 .....	1805 MHz ~ 1880 MHz .....	1710 MHz ~ 1785 MHz
4 .....	2110 MHz ~ 2155 MHz .....	1710 MHz ~ 1755 MHz
8 .....	925 MHz ~ 960 MHz .....	880 MHz ~ 915 MHz
12 .....	729 MHz ~ 746 MHz .....	699 MHz ~ 716 MHz
13 .....	746 MHz ~ 756 MHz .....	777 MHz ~ 787 MHz
20 .....	791 MHz ~ 821 MHz .....	832 MHz ~ 862 MHz

## Troubleshooting

### Errors during calibration

The error message is displayed alternately with the **ERR** message. The  icon flashes.

Error	Description	Solución
<b>E1/E2/E3</b>	Probe error 1 / 2 / 3	Check condition and wiring of affected probe
<b>E10</b>	Evaporator defrost error	Check defrost operation, it must end by temperature (d4)
<b>E20</b>	Idem for E10 but relating to the second evaporator	
<b>E11</b>	Similar temperature in probes S1 and S2	Check position of both probes following recommendations on page 8
<b>E21</b>	Idem for E11 but relating to probe S3	
<b>E12</b>	It has not been possible to carry out the calibration due to a lack of stability in the system	Avoid opening cold room door during calibration. Check main components of the refrigeration circuit, in particular the aspiration part
<b>E22</b>	Idem a E12 pero relativo al segundo evaporador	
<b>E17</b>	Excessive door openings have been detected during calibration and it has not been possible to calibrate.	Avoid opening cold room door during calibration.

### Errors during operation

The error message is displayed alternately with the temperature. The  icon flashes.

Error	Description	Solution
<b>E1/E2/E3</b>	Probe error 1 / 2 / 3	Check condition and wiring of affected probe
<b>E13</b>	Similar temperature in probes S1 and S2	Check position of both probes following recommendations on page 8
<b>E23</b>	Idem for E11 but relating to probe S3	
<b>E14</b>	A lack of stability has been detected in the system	Check main components of the refrigeration circuit, in particular the aspiration part
<b>E24</b>	Idem for E14 but relating to the second evaporator	
<b>E15</b>	Persistent lack of system stability has led to deactivation of the SELFDRIIVE mode	Check main components of the refrigeration circuit, in particular the aspiration part and the position of probe 2 or 3. To return to the SELFDRIIVE mode restart the device
<b>E25</b>	Idem for E15 but relating to the second evaporator	
<b>E16</b>	Configuration has been changed from 1 to 2 evaporators or vice versa.	If the configuration change is correct, start a manual calibration
<b>E18</b>	Excessive door openings have been detected and the device cannot regulate in SELFDRIIVE mode.	Check that the door has not been left open or that it does not open more than necessary

## Simplified declaration of conformity

AKO Electromecánica S.A.L. hereby declares that the radioelectric device types AKO-16524A and AKO-16525AN (Advanced temperature controller for cold rooms with communication) conform to the provisions set forth by Directive 2014/53/EU.

The full text of the EU conformity declaration is available at the following internet address:

<http://help.ako.com/manuales/declaracion-ue-de-conformidad>

**AKO ELECTROMECÁNICA , S.A.**

Avda. Roquetes, 30-38  
08812 • Sant Pere de Ribes.  
Barcelona • Spain

**[www.ako.com](http://www.ako.com)**

3516524A02 Rev. 11 2026