

Technical Data Sheet

Compressor model **B22G**
 Voltage **220-240V 50Hz ~1**
 Refrigerant **R134a**
 Compressor status

APPLICATION

Application High Back Pressure
 Refrigerant R134a
 Evaporating Temp. -15,0 °C to 10,0 °C
 Expansion Capillar/Valve
 Comp. Cooling Static/Fan cooled
 Max. ambient temp. 43,0 °C
 Compatible refriger. R1234yf

COMPRESSOR

Displacement 2,20 cm³
 Diameter 17,20 mm
 Stroke 9,40 mm
 Net Weight 4,60 Kg
 Oil type POE 32
 Oil charge 130 cm³
 HP 1/14 hp

MOTOR

Voltage/Frequency 220-240V 50Hz
 Voltage range 187-255 V
 Type RSIR
 Phase number 1 PH
 Locked Rotor Amps (LRA) 2,70 A
 Main W. resist. at 25°C 11,00 Ω
 Start W. resist. at 25°C 45,50 Ω

NOMINAL PERFORMANCE

	ASHRAE	CECOMAF
Cooling Capacity	160 kCal/h	152 W
COP	1,94 W/W	1,64 W/W
EER	1,67 kCal/Wh	1,42 kCal/Wh
Input Power	96 W	93 W
Current	0,72 A	0,68 A

APPROVALS

TEST CYCLE CONDITIONS

	ASHRAE HBP (D)	CECOMAF HBP (C)
Evaporating temp. (T _e)	7,2 °C	5,0 °C
Condensing temp. (T _c)	55,0 °C	55,0 °C
Liquid temp. (T _{liq.})	46,0 °C	55,0 °C
Ambient temp. (T _{amb.})	35,0 °C	32,0 °C
Suction temp. (T _{suction})	35,0 °C	32,0 °C
Voltage/Frequency	220 V 50 Hz	220 V 50 Hz

ELECTRICAL COMPONENTS

Relay	Option 1			
Reference	QP2-22 (002)			
Voltage	V			
Resistance	Ω			
Protector	Option 1	Option 2		
Reference	BT35-120A61D3 (106)	DRB14N61A1 (106)		
Current				
Time check				
Disc temp. (Open/Close)				

ASHRAE

Tc °C	Te °C	Cooling Capacity kCal/h	Consumption W	Current A	COP W/W	EER kCal/Wh
40	-15	79	63	0,56	1,46	1,25
40	-10	99	66	0,54	1,74	1,50
40	-5	125	69	0,52	2,09	1,80
40	0	157	73	0,52	2,50	2,15
40	5	195	77	0,53	2,94	2,53
40	7,2	214	79	0,53	3,15	2,70
40	10	239	82	0,55	3,41	2,94

45	-15	72	64	0,55	1,30	1,12
45	-10	89	68	0,53	1,52	1,31
45	-5	113	72	0,52	1,81	1,55
45	0	142	77	0,53	2,14	1,84
45	5	178	82	0,55	2,52	2,17
45	7,2	196	85	0,57	2,69	2,32
45	10	220	88	0,60	2,92	2,51

50	-15	64	65	0,54	1,14	0,98
50	-10	79	70	0,52	1,31	1,13
50	-5	100	76	0,52	1,54	1,33
50	0	128	81	0,55	1,83	1,57
50	5	161	87	0,60	2,15	1,85
50	7,2	178	90	0,63	2,30	1,97
50	10	201	94	0,69	2,49	2,14

55	-15	57	67	0,54	0,99	0,86
55	-10	70	72	0,52	1,12	0,96
55	-5	88	79	0,53	1,30	1,12
55	0	113	85	0,58	1,54	1,33
55	5	144	92	0,67	1,82	1,56
55	7,2	160	96	0,72	1,94	1,67
55	10	181	100	0,80	2,11	1,82

60	-15	50	68	0,53	0,85	0,73
60	-10	60	75	0,52	0,93	0,80
60	-5	76	82	0,55	1,08	0,93
60	0	99	90	0,63	1,28	1,10
60	5	127	98	0,76	1,52	1,31
60	7,2	142	101	0,83	1,63	1,40
60	10	162	106	0,94	1,78	1,53

65	-15	42	69	0,53	0,71	0,61
65	-10	50	77	0,53	0,76	0,65
65	-5	64	85	0,58	0,88	0,75
65	0	84	94	0,69	1,05	0,90
65	5	110	103	0,86	1,25	1,08
65	7,2	124	107	0,96	1,35	1,16
65	10	143	112	1,11	1,48	1,28

CECOMAF

Tc °C	Te °C	Cooling Capacity W	Consumption W	Current A	COP W/W	EER kCal/Wh
40	-15	85	63	0,56	1,34	1,16
40	-10	107	66	0,54	1,61	1,39
40	-5	135	70	0,52	1,93	1,67
40	0	169	73	0,52	2,30	1,99
40	5	210	78	0,53	2,71	2,34
40	7,2	230	80	0,54	2,89	2,50
40	10	257	82	0,55	3,14	2,71

45	-15	77	65	0,55	1,19	1,03
45	-10	96	69	0,53	1,39	1,20
45	-5	121	73	0,52	1,66	1,43
45	0	153	78	0,53	1,97	1,70
45	5	191	83	0,56	2,31	1,99
45	7,2	210	85	0,58	2,46	2,13
45	10	235	88	0,61	2,67	2,31

50	-15	68	66	0,54	1,04	0,90
50	-10	85	71	0,52	1,20	1,03
50	-5	107	76	0,52	1,41	1,22
50	0	136	82	0,55	1,66	1,44
50	5	172	88	0,61	1,95	1,69
50	7,2	189	91	0,64	2,09	1,80
50	10	213	94	0,70	2,26	1,96

55	-15	60	67	0,53	0,90	0,78
55	-10	74	73	0,52	1,01	0,87
55	-5	93	79	0,53	1,18	1,02
55	0	120	86	0,59	1,39	1,20
55	5	152	93	0,68	1,64	1,42
55	7,2	169	96	0,73	1,75	1,52
55	10	192	100	0,81	1,91	1,65

60	-15	52	68	0,53	0,76	0,66
60	-10	63	75	0,52	0,83	0,72
60	-5	80	82	0,55	0,97	0,84
60	0	103	90	0,63	1,15	0,99
60	5	133	98	0,77	1,36	1,17
60	7,2	148	102	0,84	1,46	1,26
60	10	170	107	0,96	1,59	1,38

65	-15	44	69	0,53	0,63	0,54
65	-10	52	77	0,53	0,67	0,58
65	-5	66	86	0,58	0,77	0,67
65	0	87	94	0,70	0,92	0,80
65	5	114	103	0,88	1,10	0,95
65	7,2	128	107	0,98	1,19	1,03
65	10	148	113	1,14	1,31	1,13

EN12900

X	Cooling Capacity (W)	Consumption (W)	Current (A)	Mass Flow (kg/h)
1	300,4719058078	41,3128808775	0,0527184852	5,3913207415292
2	11,9180107330	-0,8051250174	-0,0234716070	0,23010583500869
3	-3,3412225572	0,8515429545	0,0101268284	-0,042234361520896
4	0,1265884719	0,0081357662	0,0008382632	0,0036136697628762
5	-0,1117311406	0,0407636452	0,0007547816	-0,0013106291354752

Equation	$x_1 + x_2Te + x_3Tc + x_4Te^2 + x_5TeTc$
----------	---

Technical Data Sheet

COMPRESSOR DIMENSIONS

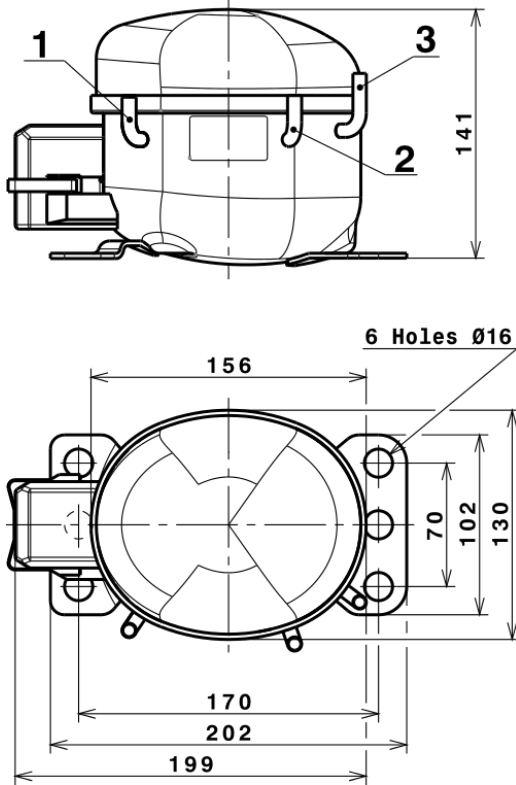

DESIGNATION	INTERNAL DIAM.
1 Suction	6,1 mm
2 Service	6,1 mm
3 Discharge	5,1 mm

WIRING DIAGRAMS AND ELECTRICAL ASSEMBLY

RSIR CONNECTION (PTC) (B, Small L ranges)

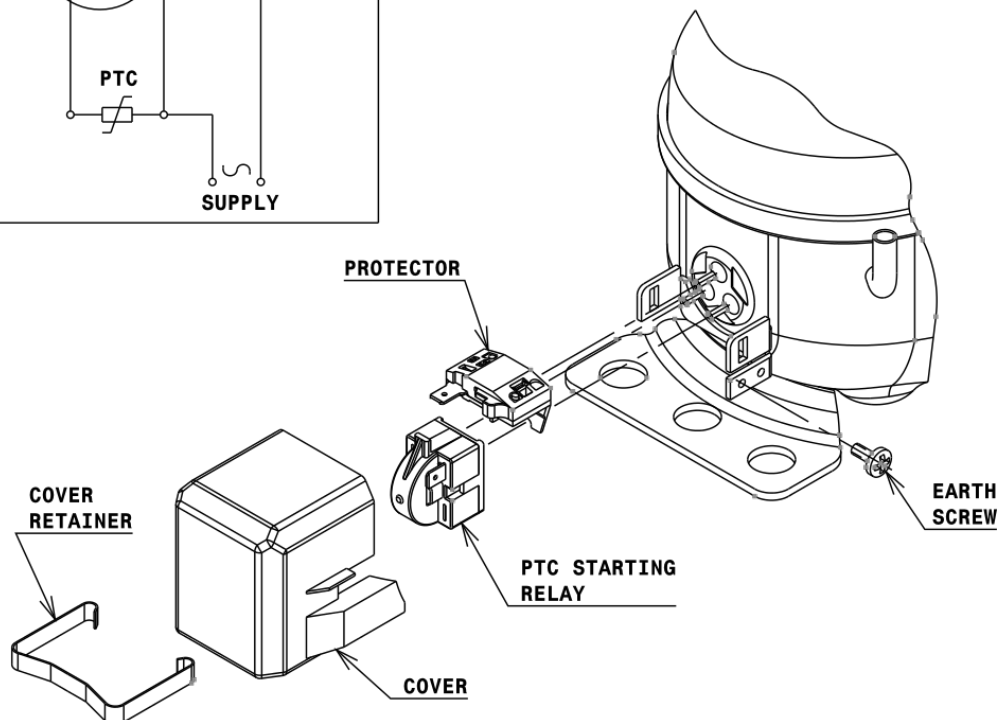
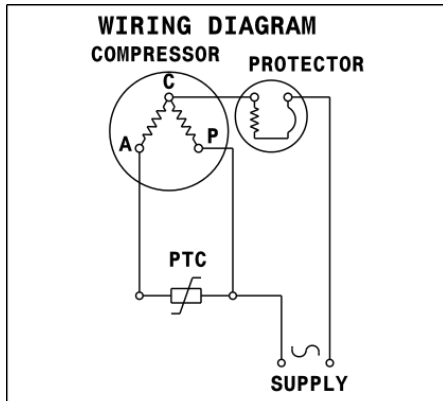

Technical Data Sheet

FIXINGS

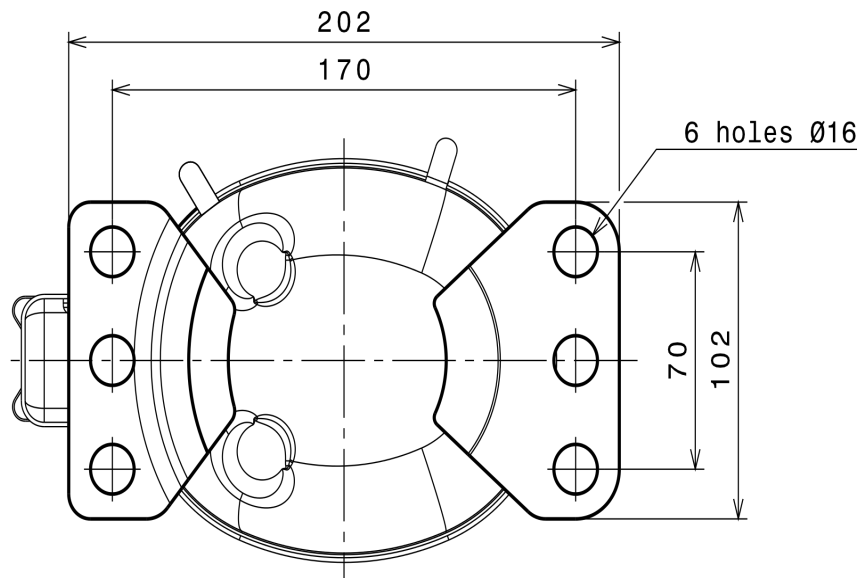

SILENT BLOCKS (MOUNTING ACCESSORIES)

STANDARD

Ø16 holes (170x70 net)

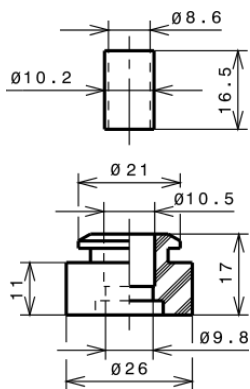

SOA

SOA R134a HBP

