



INSTRUCTION MANUAL



SZ-7521-P

GENERAL DESCRIPTION

The Sub-Zero Series SZ-7521-P are aesthetically superior versions of their predecessors. The iconic display has been specially designed to be more user friendly and gives prompt visual indications of controller operating modes. The SZ-7521-P is a defrost controller.

They are specifically designed for refrigeration applications wherein the compressor cuts off at set point and is restarted as a temperature of set point plus differential.

Additionally the SZ-7521-P offer several protection features that are easily understood by the examples in the instructions below.

A number of parameters are displayed alphanumerically to set up the instrument for each specific application.

The SZ-7521-P can be used for several applications with a measuring range from -44°C to 99°C

2

INDEX

Para.	Page	Description
	5	To set the Set Point of the controller.
	6	How to set other parameters.
P2	7	Max High Temp limit & alarm.
P3	8	Min Low Temp limit & alarm.
P4	9	To set Differential (Hysterisis.)
P5	10	Probe calibration.
P6	11	Time Delay (relay restart after cutoff)
P7	12	Defrost duration(in minutes).
P8	13	Defrost frequency(in hours).
P9	14	Converting Defrost Parameter Unit.
A1	15	Defrost duration(in seconds).
A2	16	Defrost frequency(in minutes).
LP	17	Keypad lock.
E1	18	Relay status on probe failure.
E2	19	Type of Defrost.
FS	20	Restore factory defaults.
EP	21	End Programming & keypad functions.
	22	Operating messages.

3

INDEX

Para.	Page	Description
	23	Technical Data.
	24	Suggested Wiring Diagram.
	25	Panel cutout & dimensions.
	26	Installation & Maintainance

4

Set point			Function: To set the cut out point of the controller.
Press and hold the SET key for 2 seconds.			Display will change to set value and LED will flash. The set point value can now be changed by using the UP/DOWN keys. After setting the desired value, press the set key and you will see " _ _ " which confirms that the set point has been stored in memory.
Min	Max	Fac.	
P3+1	P2-1	0°C	
SET			

5

To set other parameters.	
Press & Hold Down (prg) Key for 2 seconds.	Display will show P2 & flash To go to other parameters , use up / down keys.
	

6

P2 parameter	Function : To set maximum allowable high temperature limit.	
To change the P2 parameter, press the SET key.	Use up/down keys to set desired value. Once set at a particular value, this will not allow the set point to go above this value and below P3 setting.	
Min	Max	Fac.
SP+1	99°C	99°C
Ht (Message on display)	Example : Setting this parameter at -25°C will not allow the set point to go above -25°C. Also, if the temperature reaches -25°C, the display will show Ht (High Temp.) indicating that the temperature has gone above the value in this parameter.	

7

P3 parameter	Function: To set minimum allowable low temperature set point	
To change the P3 parameter, press the SET key.	Use UP/DOWN keys to set desired value. Once set at a particular value, this will not allow the set point to go below this value and above P2 setting.	
Min	Max	Fac.
-44°C	SP-1	-44°C
Lt (Message on display)	Example: Setting this parameter at -30°C will not allow the set point to go below -30°C. Also, if the temperature reaches -30°C, the display will show Lt (Low Temp.) indicating that the temperature has reached or gone below the value in this parameter	



8

P4 parameter	Function: To set the differential.	
To change the P4 parameter, press the SET key.	Use UP/DOWN keys to set desired value. Differential between cut out and cut in temperature can be set between 1°C to 20°C.	
Min	Max	Fac.
1°C	20°C	2°C
	Example (in cooling mode) : If the set point is set at 10°C and differential is set at 2°C, then when the system reaches 10°C, the relay will cut out. Since the differential is 2, the relay will cut in (restart) at 12°C (10°C+2°C).	

9

P5 parameter	Function: To set probe calibration.	
To change the P5 parameter, press the SET key.	Use UP/DOWN keys to set desired value. In time it may be possible that the display may be offset by a degree or so. To compensate for this error, you may need to add or minus the degrees required to achieve the correct temperature. Setting value is from -10°C to + 10°C	
Min	Max	Fac.
-10°C	10°C	0°C
	Example: The temperature on the display is 28°C, whereas the actual temperature is 30°C. You will need to set the P5 mode to 2, which means that once out of the programming mode, the display will show the temperature 30°C (28°C + 2°C).	

10

P6 parameter	Function: To set time delay between relay restart time.	
To change the P6 parameter, press the SET key.	Use UP/DOWN keys to set desired value. This parameter is used to protect the compressor from restarting in a short period of time and can be set between 0 to 99 minutes.	
Min	Max	Fac.
0	A2-1	3
Units : Min		
		Example: If this parameter is set at 3 minutes, the relay will cut off at the set temperature, but will not restart for a minimum of 3 minutes, even if the differential is achieved earlier. This parameter is good to protect the life of the compressor or even in applications where the probe is placed at places where there are sudden & short changes in temperature like above a cold room door.

11

P7 Parameter	Function : To set duration of defrost(in minutes).		
To change the P7 parameter, press the SET key.	Use up/down keys to set desired value. This parameter is used for auto defrost cycle and specifies how long will a defrost last.		
Min	Max	Fac.	
0 Min	99 Min	0 Min	
			
Example : If this parameter is set to 15 min, and P8 parameter is set to 1 hr. The '1 hr' after power is applied to the controller, defrosting for 15 mins will take place. This cycle will repeat every 1 hr.			

12

P8 parameter	Function : To set the defrost frequency(in hours).		
To change the P8 parameter, press the SET key.	Use the UP/DOWN keys to set desired value. This Parameter is used for auto defrost cycle and specifies, when each defrost cycle will be repeated.		
Min	Max	Fac.	
1 Hr	31Hrs	1 Hr	
			
Example : See P7 parameter.			

13

P9 parameter	Function : Converting Defrost Parameter Unit.		
To change the P9 parameter, press the SET key.	Use up/down keys to set desired value. When this parameter is set to 0, it takes P7 and P8 value for defrost (Mins. for Duration & Hrs. for Frequency) When this parameter is set to 1, it takes A1 & A2 value for defrost (Secs. for Duration & Mins. for Frequency)		
Min	Max	Fac.	
0	1	0	
			

14

A1 Parameter	Function :To set duration of defrost(in seconds).		
To change the A1 parameter, press the SET key.	Use up/down keys to set desired value. This parameter is used for auto defrost cycle and specifies how long will a defrost last.		
Min	Max	Fac.	
0 Sec	99 Sec	10 Sec	
			
Example : If this parameter is set to 15 sec, and A2 parameter is set to 4 min. Then '4 min' after power is applied to the controller, defrosting for 15 sec will take place. This cycle will repeat every 4 min.			

15

A2 Parameter	Function : To set the defrost frequency(in minutes).		
To change the A2 parameter, press the SET key.	Use the UP/DOWN keys to set desired value. This Parameter is used for auto defrost cycle and specifies, when each defrost cycle will be repeated.		
Min	Max	Fac.	
(P6+1)Min.	99Min.	4Min.	
			
Example : See A1 parameter.			

16

LP parameter	Function : To lock keypad.		
To change the LP parameter, press the SET key.	Use up/down keys to set desired value. This Parameter can lock the keypad so that tampering is not possible by by-standers.		
Min	Max	Fac.	
0	1	0	
			
0= keypad unlocked 1= keypad locked When locked all parameters can only be viewed, but not modified.			

17

E1 Parameter	Function : Relay status on Probe Failure.		
To change the E1 parameter, press the SET key.	Use UP/DOWN keys to set desired value. When set to 0 the relay status is ON. When set to 1, the compressor performs a duty cycle of 10 minutes ON and 4 minutes OFF. When set to 2 the relay status is OFF.		
Min	Max	Fac.	
0	2	1	

18

E2 Parameter	Function : Type of Defrost.		
To change the E2 parameter, press the SET key.	Use UP/DOWN keys to set desired value. 0 = Electrical Defrost (Comp is off) 1 = Hot gas Defrost (Comp is on) 2 = Air Dryer Defrost. (Compressor does not respond to defrost and cuts on/off at its own set point.)		
Min	Max	Fac.	
0	2	2	

19





FS Parameter	Function : To restores default settings of the controller.		
To change the FS parameter, press the SET key.	When set to 1 all parameters are programmed to factory values. Useful to debug setting related problems.		
Min	Max	Fac.	
0	1	0	

20

EP Parameter	Function : To end programming.		
To end programming press the SET key	Once the set key is pressed, the controller goes into the normal mode and displays the temperature and all settings are recorded.		
Manual Defrost 	This key will start a manual defrost cycle if pressed for 2 sec. Press again for 2 seconds it will come out of defrost mode and STOP defrost cycle.		

21

Operating messages and Icon status

Message	Description	Parameter
Ht	Temperature above the maximum limit of the set point.	P2
Lt	Temperature below the minimum limit of the set point.	P3
PP	Probe short circuit, circuit open or without probe, or temperature > 99°C or < -44°C	
 On/Off	Compressor Relay On/Off.	SP, P4
 On/Off	Keyboard locked/unlocked.	LP
 On	Defrosting in progress	P7, P8 / A1, A2
 Flashing	Time delay in progress	P6

22

Technical data :

Housing	: Black ABS plastic.
Front cover	: Red Polycarbonate plastic.
Dimensions	: Front - 75 x 34.5 mm, Depth - 71 mm.
Mounting	: Flush panel mounting with fasteners.
Protection	: Front panel is waterproof & I.P 65 rated .
Connections	: Screw terminal blocks. ≤ 2.5 mm ² , one wire /Terminal only
Display	: 14.2 mm (0.56") LED.
Data storage	: Flash APROM Memory
Power input	: 230Vac, +/-10%, 50/60Hz Standard.
Operating temp.	: 0°C to 60°C(non-condensing).
Operating humidity	: 20% to 85% (non-condensing)
Storage temp	: -25°C to 60°C(non-condensing).
Output	: 1 SPDT Comp. relay 10(1)A, 250Vac 1 SPDT Defrost relay 10(1)A, 250Vac
Input	: NTC Probe-SZ-T75
Range	: -44°C to 99°C
Resolution	: 1°C
Accuracy	: +/-1°C

23

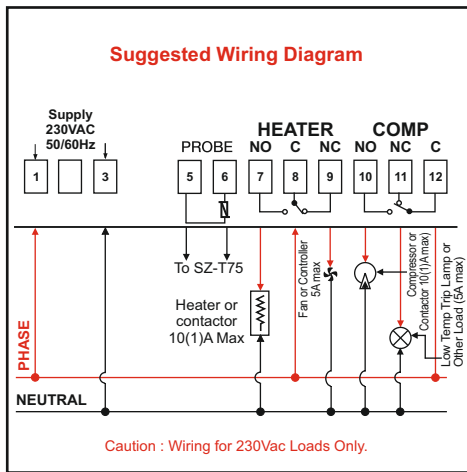

24

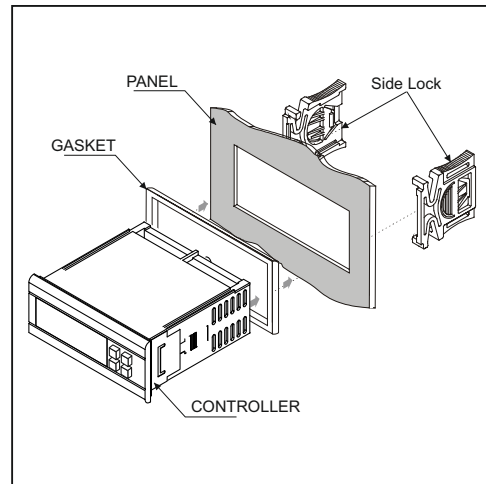

25

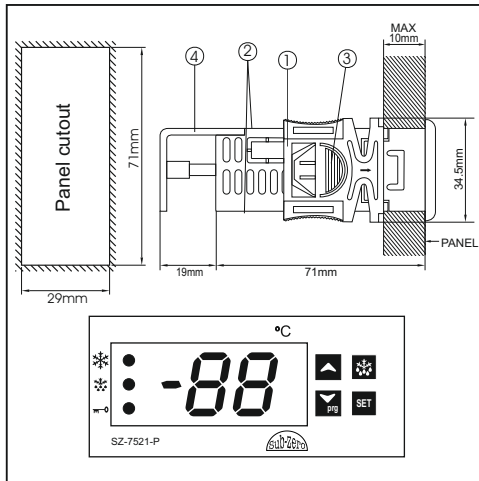

26

Installation : Fixing and dimensions of panel models:

To fix the unit, slide the fastener ① through the guides ② as per the position shown in the figure. Move the fastener in the direction of the arrow, pressing tab ③ it permits to move the fastener in the opposite direction of the arrow. Once the controller has been connected, they should be covered with the Backlid ④ (Optional). Silicon sealant should be applied along the perimeter of the panel cut out or a rubber 'O' ring supplied before the unit is fitted to obtain IP65 grade.

Controller : Controller should be installed in a place protected by vibration, water and corrosive gasses and where ambient temperature does not exceed the values specified in the technical data.

Probe : To give a correct reading, the probe must be installed in a place protected from thermal influences, which may affect the temperature to be controlled.

27

CAUTION

WIRING: The probe and its corresponding wires should never be installed in a conduit next to control or power supply lines. The electrical wiring should be done as shown in the diagram. The power supply circuit should be connected to a protection switch. The terminals admit wires of upto 2.5sq mm.

WARNING: Improper wiring may cause irreparable damage and personal injury. Kindly ensure that wiring is done by qualified personnel only.

Maintenance : Cleaning: Clean the surface of the controller with a soft moist cloth. Do not use abrasive detergents, petrol, alcohol or solvents.

Notice : The information in this document is subject to change in order to improve reliability, design or function without prior notice and does not represent a commitment on the part of the company. In no event will the company be liable for direct, indirect, special, incidental or consequential damage arising out of the use or inability to use the product or documentation, even if advised of the possibility of such damages. No part of this manual may be reproduced or transmitted in any form or by any means without the prior written permission of the company.

28

Disclaimer: These manual & its contents remain the sole property of PVR CONTROLS, India and shall not be reproduced or distributed without authorization. Although great care has been taken in the preparation of this document, the company or its vendors in no event will be liable for direct, indirect, special, incidental or consequential damage arising out of the use or inability to use the product or documentation, even if advised of the possibility of such damages. No part of this manual may be reproduced or transmitted in any form or by any means without the prior written permission of the company. PVR CONTROLS, reserves the right to make and changes or improvements without prior notice.

Warranty: This product is warranted against defects in materials and workmanship for a period of one year from the date of purchase. During the warranty period, product determined by us to be defective in form or function will be repaired or, at our option, replaced at no charge. This warranty does not apply if the product has been damaged by accident, abuse, and misuse or as a result of service or modification other than by the company. This warranty is in lieu of any other warranty expressed or implied. In no event shall the company be held liable for incidental or consequential damages, including lost revenue or lost business opportunity arising from the purchase of this product.

29



INDIA

OUR OTHER PRODUCTS

Cold Room Controller

Chiller Controller

Two Compressors Controller

Heating Controller

Humidity Controller

Pressure Controller



Ball Valves

Globe Valves

Hand Valves

Flow Switches

Solenoid Valves

REV1 - 27.07.2024