

# SZ-7520T / SZ-7529T



## Operating Instructions



### Touch Sensitive Temperature Controller

#### Introduction :

The new SZ-7520T/7529T are the next generation of Subzero controllers. Their IP ratings are greatly improved and have an excellent iconic display. The touch feature whilst increasing reliability also gives a great user experience.

These controllers designed for refrigeration have several features specially designed for safety of compressors. They work on the system that the compressor cuts off at set point and is restarted at a temperature of set point + differential.

Their operation is very user friendly and is easily understood with the examples in the instructions below.

Various parameters help set up the instruments functions for different applications.

The SZ-7520T/7529T is specifically designed for defrost applications with a measuring range from -45°C to 99°C.

#### CAUTION

**WIRING:** The probe and its corresponding wires should never be installed in a conduit next to control or power supply lines. The electrical wiring should be done as shown in the diagram. The power supply circuit should be connected to a protection switch. The terminals admit wires of upto 2.5sq mm.

**WARNING:** Improper wiring may cause irreparable damage and personal injury. Kindly ensure that wiring is done by qualified personnel only.

**Maintenance:** Cleaning: Clean the surface of the controller with a soft moist cloth. Do not use abrasive detergents, petrol, alcohol or solvents.

**Notice:** The information in this document is subject to change in order to improve reliability, design or function without prior notice and does not represent a commitment on the part of the company. In no event will the company be liable for direct, indirect, special, incidental or consequential damage arising out of the use or inability to use the product or documentation, even if advised of the possibility of such damages. No part of this manual may be reproduced or transmitted in any form or by any means without the prior written permission of the company.

**Installation:** Fixing and dimensions of panel models:

To fix the unit, slide the fastener ① through the guides ② as per the position shown in the figure. Move the fastener in the direction of the arrow, pressing tab ③ it permits to move the fastener in the opposite direction of the arrow.

**Controller:** Controller should be installed in a place protected by vibration, water and corrosive gasses and where ambient temperature does not exceed the values specified in the technical data.

**Probe:** To give a correct reading, the probe must be installed in a place protected from thermal influences, which may affect the temperature to be controlled.

#### Panel Cutout and Dimensions :

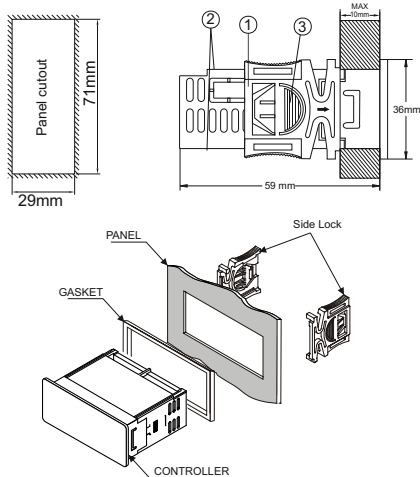

#### Suggested Wiring SZ-7520T (230Vac)

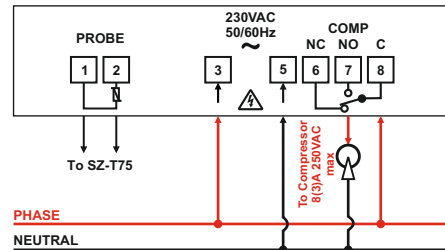

Caution:Wiring for 230Vac load only

#### Suggested Wiring SZ-7529T (230Vac)

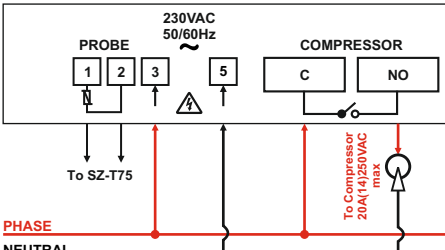

Caution:Wiring for 230Vac load only

#### Suggested Wiring SZ-7520T

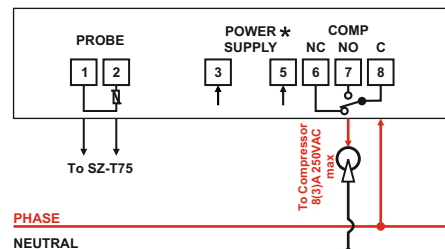

\*12Vac/dc or 24Vac/dc or 48Vdc

#### Suggested Wiring SZ-7529T

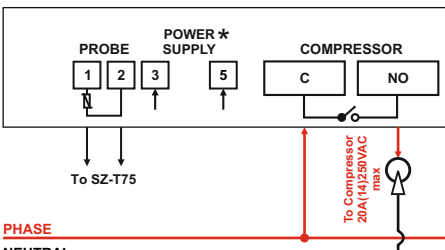

\* 12Vac/dc or 24Vac/dc or 48Vdc or 110Vac

#### TECHNICAL DATA

<b>Housing</b>	: Black ABS Plastic, Auto-extinguish
<b>Front Cover</b>	: Polycarbonate Plastic
<b>Dimensions</b>	: Frontal : 78 X 36mm, Depth : 59mm
<b>Panel Cutout</b>	: 29 X 71mm
<b>Mounting</b>	: Flush panel mounting with fasteners
<b>Protection</b>	: IP65 Front (with gasket)
<b>Connections</b>	: Screw terminal blocks. ≤ 2.5sq mm terminal only.
<b>Display</b>	: 2 X 17mm 7 segment display & 5 LEDs for Indication
<b>Data storage</b>	: Flash APROM memory
<b>Power input</b>	: 230 Vac ±10% , 50/60Hz. Others on request.
<b>Relay output</b>	: Comp SPST relay 20(14)A,250V AC(for SZ-7529T) Comp SPDT relay 8(3)A,250V AC(for SZ-7520T)
<b>Operating temp.</b>	: 0°C to 60°C (non-condensing)
<b>Operating humidity</b>	: 20% to 85% (non-condensing)
<b>Storage temp</b>	: -25°C to 60°C (non-condensing)
<b>Measuring Range</b>	: -45°C to 99°C
<b>Input</b>	: NTC Probe-SZ-T75.
<b>Resolution</b>	: 1°C
<b>Accuracy</b>	: +/- 1°C

#### USER INTERFACE

<b>UP</b>	In Program mode: <b>Scroll through parameters &amp; Increases parameter value.</b> In Set mode : <b>Increases parameter value.</b>
<b>Down/Program</b>	Touch and hold for 2sec <b>to enter into program mode.</b> In program mode and set mode: <b>Decreases parameter value</b>
<b>Defrost</b>	Touch & hold for 2 sec to start a <b>manual defrost and to stop Auto / Manual defrost cycle.</b>  Also used to Exit from program mode.
<b>SET Set</b>	Touch and hold for 2sec <b>to enter into set mode.</b> In program mode and set mode: <b>set/save the changed value of parameter.</b>

#### INDEX

Sr. No.	Para.	Description
1	Set Point	Compressor relay set point.
2		Set other parameter.
3	P2	High temperature limit.
4	P3	Low temperature limit.
5	HS	Maximum Set Point limit.
6	LS	Minimum Set Point limit.
7	P4	Differential for compressor relay ON condition.
8	P5	Probe calibration.
9	P6	Time delay (compressor relay restart after cutoff).
10	Ot	Minimum ON time for compressor relay.
11	E1	Compressor relay status in probe fail.
12	Cn	Compressor relay OFF time during probe fault.
13	Cy	Compressor relay ON time during probe fault.
14	P7	Duration for Defrost Cycle.
15	P8	Frequency for Defrost Cycle.
16	dF	Display while the Defrost Cycle is in progress.
17	dd	Delay the display of temperature.
18	Ad	Time delay at Power ON for alarm indication.
19	PA	Change Password
20	LP	Keypad Lock
21	FS	Restore factory defaults
22	EP	End Programming
23		LED Indications
		Operating Messages (Normal Mode)
		Operating Messages (Pro-key Mode)
		Password Function
		Temperature Logging

#### Parameter List :

<b>1 Set point</b>	Function: To set compressor relay set point.  Touch & hold <b>SET</b> key for 2 seconds.
<b>2 To set other Parameters.</b>	Display will flash "P2". To select other parameters, use UP/DOWN keys.  Touch & hold <b>PRG</b> key for 2 seconds.

Min	Max	Fac.
LS+1	HS-1	0°C

<b>3 P2 Parameter</b>	Function: To set maximum allowable high temperature limit.
-----------------------	------------------------------------------------------------

To change value use **UP** **PRG** keys To set value touch "SET" key

**Example:** If this parameter is set to 50°C and the temperature reaches or goes above 50°C, display will show Ht (High Temp.) indicating that the temperature has reached or gone above the value set in this parameter.

Min	Max	Fac.
P3+1	99°C	99°C

<b>4 P3 Parameter</b>	Function: To set minimum allowable low temperature limit.
-----------------------	-----------------------------------------------------------

**Example:** If this parameter is set to -10°C and the temperature reaches or goes below -10°C, display will show Lt (Low temp.) indicating that the temperature has reached or gone below the value set in this parameter.

Min	Max	Fac.
-40°C	P2-1	-40°C

<b>5 HS Parameter</b>	Function: To set Maximum set point limit.
-----------------------	-------------------------------------------

Once set at a particular value, this will not allow the set point to go above this value.

**Example:** Setting this parameter at 25°C will not allow the set point to go above 24°C (HS-1).

Min	Max	Fac.
SP+1	99°C	99°C

<b>6 LS Parameter</b>	Function: To set Minimum set point limit.
-----------------------	-------------------------------------------

Once set at a particular value, this will not allow the set point to go below this value.

**Example:** Setting this parameter at -10°C will not allow the set point to go below -9°C (LS+1).

Min	Max	Fac.
-40°C	SP-1	-40°C

<b>7 P4 Parameter</b>	Function: To set the differential for compressor relay ON condition.
-----------------------	----------------------------------------------------------------------

**Example :** If the set point is set at 10°C and differential is set at 2°C, then when the system reaches 10°C, the compressor relay will go OFF. Since the differential is 2°C, the compressor relay will come ON (restart) at 12°C (10°C + 2°C).

Min	Max	Fac.
1°C	20°C	2°C

<b>8 P5 Parameter</b>	Function: To set probe calibration.
-----------------------	-------------------------------------

In time it may be possible that the display may be offset by a degree or so.

To compensate for this error, user may need to add or minus the degrees required to achieve the correct temperature.

**Example :** The temperature on the display is 28°C, whereas the actual temperature is 30°C. User will have to set the P5 parameter to 2, which means that once out of the programming mode, the temperature on display will be 30°C (28°C + 2°C).

Min	Max	Fac.
-10°C	10°C	0°C

<b>9 P6 Parameter</b>	Function: To set time delay between compressor relay restart.
-----------------------	---------------------------------------------------------------

This parameter is used to protect the compressor from restarting in a short period of time.

**Example:** If this parameter is set at 3 minutes, the compressor relay goes OFF at the set point, it will not restart for a minimum of 3 minutes, even if the differential is achieved earlier. This parameter is good to protect the life of the compressor.

Min	Max	Fac.
0 Min	99 Min	3 Min

<b>10 Ot Parameter</b>	Function: Minimum ON Time For Compressor relay.
------------------------	-------------------------------------------------

This parameter is used to protect the compressor so that there is enough time for oil to return back to the compressor. This delay starts once the compressor relay is ON.

**Example:** If this parameter is set at 1Min and if the temperature is achieved before 1 minute, then the compressor relay will remain ON for minimum 1 minute, though set point is achieved.

Min	Max	Fac.
0 Min	20 Min	0 Min

**11 E1 Parameter** Function : Compressor relay status in case of Probe Failure.

When set to  
 0 = Compressor relay status is OFF.  
 1 = Compressor relay status is ON.  
 2 = Compressor relay performs a duty cycle for Cn for minutes OFF and Cy for minutes ON.

Min	Max	Fac.
0	2	2

**12 Cn Parameter** Function : Compressor relay OFF Time during probe fault.

(This will be considered only when E1 is selected 2 ).

**Example :** If this parameter is set to 4 minutes, then compressor relay will be OFF for 4 minutes while performing the duty cycle.

Min	Max	Fac.
1 Min	99 Min	4 Min

**13 Cy Parameter** Function : Compressor relay ON Time during probe fault.

(This will be considered only when E1 is selected 2 ).

**Example :** If this parameter is set to 10 minutes, then compressor relay will be ON for 10 minutes while performing the duty cycle.

Min	Max	Fac.
1 Min	99 Min	10 Min

**14 P7 Parameter** Function : This Parameter is used to set the Duration for Defrost Cycle.

This paramter is applicable for both Auto and Manal Defrost and specifies for how much time the Defrost will last.

**Example :** If this parameter is set to 30 Minutes and Defrost Frequency means P8 parameter is set to 1 Hour, then 1 Hour after Power is applied to the controller, defrost will take place for 30 minutes. This Cycle will repeat after every 1 Hour.

Min	Max	Fac.
0 Min	99 Min	30 Min

ON  
Defrost in Progress

**15 P8 Parameter** Function : This Parameter is used to set the frequency for Defrost Cycle.

This parameter is applicable only for Auto Defrost.

**Example :** As explained for P7 parameter.

Min	Max	Fac.
1 Hr	31 Hr	6 Hr

**16 dF Parameter** Function : This parameter is used to select display while the Defrost Cycle is in progress.

**Example :** When this parameter is set to,

0: While the Defrost is ON , Control Probe temperature will be displayed.

1: While the Defrost is ON, "dF" will be displayed.

Min	Max	Fac.
0	1	0

**17 dd Parameter** Function : This parameter is used to delay the display of temperature by the set in this parameter.

Each value corresponds to 5 seconds, if the value is set to 1, it corresponds to 5 seconds, if it is set to 2, it corresponds to 10 seconds and so on.

For example, if this parameter is set to 1, temperature on the display will be updated after 5 seconds. The same value will be considered for calculation and logging.

Display delay parameter is applicable only when temperature is increasing (rising). When temperature is decreasing (falling) this parameter will not be applicable.

If this parameter is set to 0, this feature will be disabled.

Min	Max	Fac.
0	36	0

**18 Ad Parameter** Function : This parameter is used to set the time delay at Power ON for Alarm Indication.

**Example:** If this parameter is set to 20 minutes, once the controller is powered ON, no fault indication will be activated for 20 minutes.

Alarm delay is used only for High Temperature and Low Temperature, but not for Room Sensor fail.

If Control Probe Temperature reaches or goes above P2 parameter value, High Temperature (Ht) fault will displayed.

If Control Probe Temperature reaches or drops below P3 parameter value, Low Temperature (Lt) fault will displayed. Differential of 1°C is considered for clearing the fault.

ON  
Fault is present

Min	Max	Fac.
0 Min	99 Min	0 Min

**19 PA Parameter** Function : To change Password.

User cannot enter into program mode & set mode, if correct password is not entered.

If the password is kept other then 0, user need to enter correct password to enter into set/program mode.

If password is 0, user can directly access set/program mode.

Min	Max	Fac.
-99	99	0

**20 LP Parameter** Function: To lock keypad.

This parameter is used to lock the keypad so that tampering is not possible by by-standers.

0 = keypad unlocked  
 1 = keypad locked

When locked all parameters can only be viewed, but not modified.

**Note :** If LP parameter is set to 1 and if user tries to change any parameter value, "LP" will flash on the display.

Min	Max	Fac.
0	1	0

LP  
Flashing

**21 FS Parameter** Function : To restore default settings of the controller.

When set to 1 all parameters are programmed to factory set values. Useful to debug setting related Problems.

When set to,  
 0 = FS is disable.  
 1 = FS as per default value.

Min	Max	Fac.
0	1	0

**22 EP Parameter** Function: To end programming.

To end programming press "SET" key

Once the key is pressed, the controller goes into the normal mode and displays the temperature and all settings are recorded.

**LEDS**

<b>Compressor</b> ON: Compressor is ON. OFF: Compressor is OFF.	<b>Alarm</b> ON: Alarm relay ON. OFF: Alarm relay OFF.
<b>Time Delay</b> ON: Compressor is ON and in time delay for switching OFF. (Ot parameter) FLASHING: Compressor is in time delay and about to start.	<b>Defrost</b> ON: Defrost in progress.

°C ON: When temperature is displayed.

**OPERATING MESSAGES (Normal Mode)**

<b>Ht High temperature alarm</b> Temperature above the maximum high temperature limit.	<b>Lt Low temperature alarm</b> Temperature below the minimum low temperature limit.
<b>PP Probe fail</b> Probe short circuit, circuit open or without probe, or temperature is > 99°C or <-40°C	<b>LP Keypad lock</b> Keypad is locked
<b>LL Last low temperature</b> Last low temperature logged.	<b>LH Last high temperature</b> Last high temperature logged.
<b>rs</b> In log function: When LL and LH values are cleared.	<b>dF Defrost</b> Defrost in progress.

**Password function**

●In Program mode:  
 Touch & hold "PRG" key for 2sec. Display will flash "P2" parameter if "PA" value is kept "0". If other than "0", then "PA" and "0" will flash. Use "▲" and "▼" keys to enter the password. On entering correct value, display will flash the first parameter "P2". User can scroll through parameters using "▲" or "▼" keys.

●In Set mode:  
 Touch & hold "SET" key for 2sec. Display will flash set point value if "PA" parameter value is kept to "0". If other than "0", then display will flash "PA" and "0". Use "▲" or "▼" to enter the password. On entering correct value, display will flash set point value. User can set desired value using "▲" or "▼" keys. To save the modified value use "SET" key.

**High and Low temperature logging function**

●How to see the logged values:  
 LL : Last Low temperature  
 LH : Last High temperature

Touch and hold "▲" key for 1sec. display will flash "LL" and the corresponding temperature for 4 seconds. After this, display will flash "LH" and the corresponding temperature for 4 seconds and come out of Log mode and will display Control probe temperature.

●How to reset the Logged values  
 While the display is showing the logged values, if user touches & holds the "SET" key for 1sec, the logged values will be cleared and "rs" will be displayed.  
 Log Values will get reset after Power ON/OFF.

**Disclaimer:** This manual & its contents remain the sole property of PVR CONTROLS . India and shall not be reproduced or distributed without authorization. Although great care has been taken in the preparation of this document, the company or its vendors in no event will be liable for direct, indirect, special, incidental or consequential damage arising out of the use or inability to use the product or documentation, even if advised of the possibility of such damages. No part of this manual may be reproduced or transmitted in any form or by any means without the prior written permission of the company. PVR CONTROLS., reserves the right to make and changes or improvements without prior notice.

**Warranty:** This product is warranted against defects in materials and workmanship for a period of one year from the date of purchase. During the warranty period, product determined by us to be defective in form or function will be repaired or, at our option, replaced at no charge. This warranty does not apply if the product has been damaged by accident, abuse, and misuse or as a result of service or modification other than by the company. This warranty is in lieu of any other warranty expressed or implied. In no event shall the company be held liable for incidental or consequential damages, including lost revenue or lost business opportunity arising from the purchase of this product.

**OUR OTHER PRODUCTS**

Controlled cooling, always	
Cold Room Controller Chiller Controller Two Compressor Controller Heating Controller Humidity Controller Pressure Controller	Ball Valves Globe Valves Hand Valves Flow Switches Solenoid Valves

REV1 - 22.07.2024