

APPROVAL SHEET

SPECIFICATIONS OF HUAYI R134a COMPRESSOR

MODEL NAME: E55HBL

BUYER:

PRINTED DATE: October 9, 2019

MANUFACTURER

HUAYI COMPRESSOR (JINGZHOU) CO., LTD.

华意压缩机(荆州)有限公司

SPECIFICATION

● CUSTOMER:

FROM: HUAYI COMPRESSOR (JINGZHOU) CO., LTD.

● MODEL: E55HBL

华意压缩机(荆州)有限公司

DATE: October 9, 2019

● RATED VOLTAGE & FREQUENCY: 220-240V/50Hz

PREPARED	CHECKED	APPROVED
Wang Zhongwei	Fan HongXing	Zhang Changxiang

● SPEC. NO.:

● PARTS LIST

PART LIST		HUAYI SUPPLY	PART NO.	QTY	SPECIFICATION
COMPRESSOR	PERFORMANCE				
COMPRESSOR	WIRING DIAGRAM				
COMPRESSOR	EXPLODED VIEW				
ELECTRICAL PARTS	OLP + Spring taps			1	DRB135P61A2/BT27-125A61D3/ BT27-125 (132)
ELECTRICAL PARTS	STARTING DEVICE			1	QP2-22/QP2-22/JPQ II -22 (015)
ELECTRICAL PARTS	RUNNING CAPACITOR			1	3 μ F
ELECTRICAL PARTS	TERMINAL COVER + SPRING TAPS			1	PC, SPRING STEEL
ELECTRICAL PARTS	EARTH BOLT			1	
MOUNTING PARTS	SEAT RUBBER			4	
MOUNTING PARTS	MOUNTING SLEEVE			4	
MOUNTING PARTS	FLAT WASHER			4	

CUSTOMER' S MEMO

CUSTOMER' S APPROVAL

Checked by:

Approved by:

*Please return one copy of this page on your approval.

20191009-E55HBL

4-1

Performance & Dimension

Application

Type	Low Back Pressure
Evaporating Temp. Range...	-35°C to -15°C(-31°F to 5°F)
Refrigerant.....	R134a
Refrigerant control.....	Capillary tube
Compressor cooling	Static cooling

Normal Performance (ASHRAE) 50Hz

Capacity	Watt±5%	145
	Kcal/h±5%	124.7
	BTU/h±5%.....	494.7
Power consumption	W+15%	100
C. O. P.	W/W±5%.....	1.45
EER	BTU/(W. h) ±5%.....	4.95
NOISE	dB(A)	45

Testing condition

Evaporation Temp.	-23.3°C (-10°F)
Condensing Temp.	54.4°C (130°F)
Ambient Temp.	32.2°C (90°F)
Return Gas Temp.	32.2°C (90°F)
Liquid Temp.	32.2°C (90°F)

Compressor Date

Design.....	Reciprocating
Displacement.....	5.6cm ³

Suction Tube I.D.....	I. D φ 6.10 ~ φ 6.20mm
Process Tube I.D.....	I. D φ 6.10 ~ φ 6.20mm
Discharge Tube I.D.....	I. D φ 4.90 ~ φ 5.00mm

Weight(with oil charge)..... 8.0Kg

Motor Date

Motor type	RSCR
Motor protection.....	External protection
Winding Insulation Class	E Class

EXPLODED VIEW

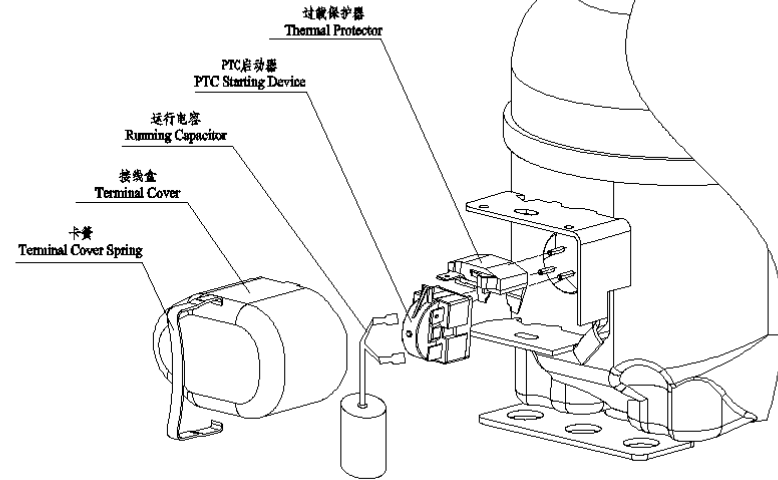

OVERALL DIMENSION

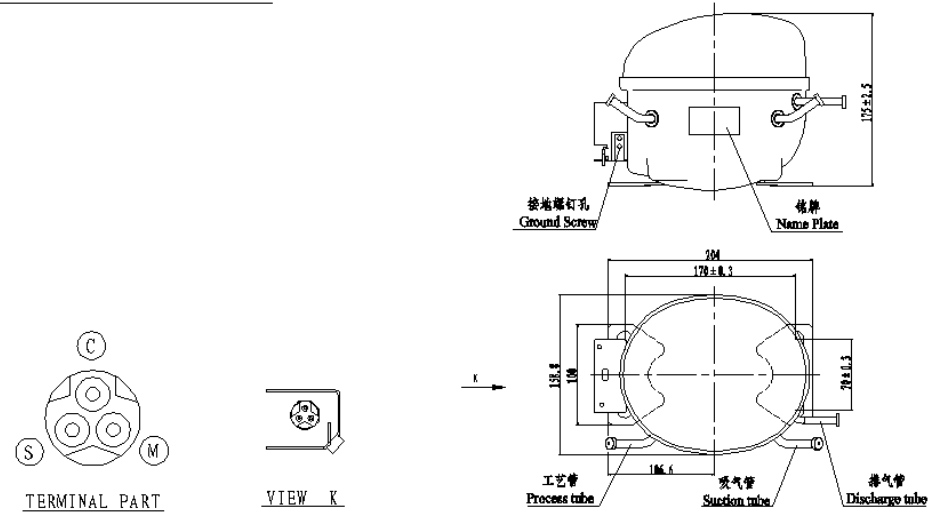

Electrical components

Overload protector..... DRB135P61A2/BT27-125A61D3/BT27-125

Ultimate Trip current (at 90°C) ... 0.7~1.0A

Opening temperature..... 125±5°C

Closing temperature..... 61±9°C

Manufacture..... Star Shuaier/Sen Bao/Lan Xi

Starting Device QP2-22/QP2-22/JPQ II -22

Manufacture Star Shuaier/Sen Bao/Lan Xi

Running Capacitor Capacity 3 μF

Voltage..... 450V

Starting Capacitor Capacity..... N. A.

Voltage..... N. A.

Lubricant

Lubricant type..... Polyol Ester (POE)

Lubricant Viscosity at 40°C

Domestic..... RB-15HY-SN

Export..... RB-15HY-SN

Initial charge 250±10ml

Recharge 85%

Tray Holder N. A.

Earth plate..... N. A.

Approved Certification..... N. A.

Wire Drawing

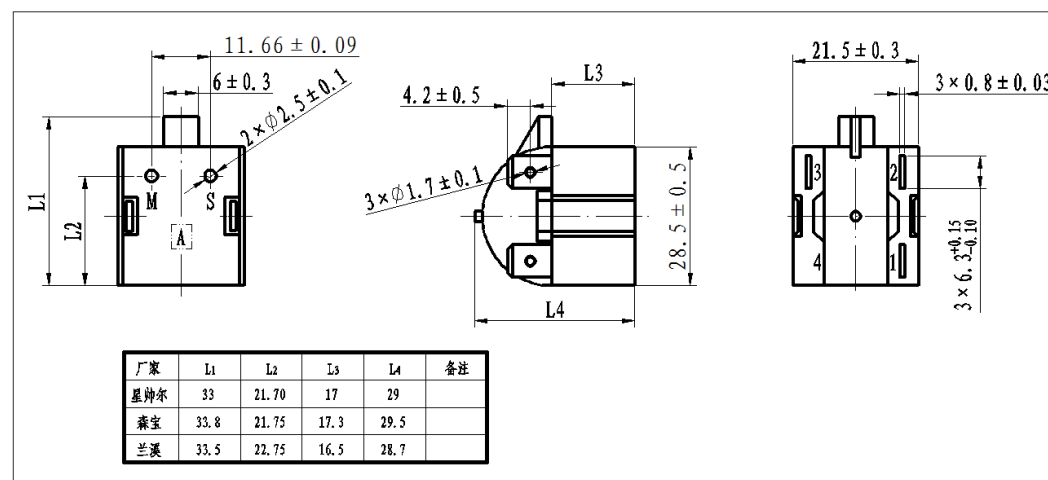
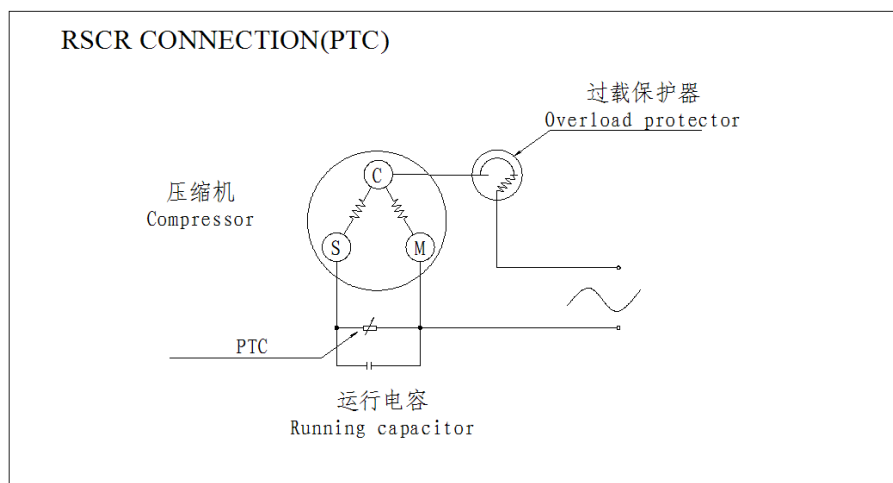
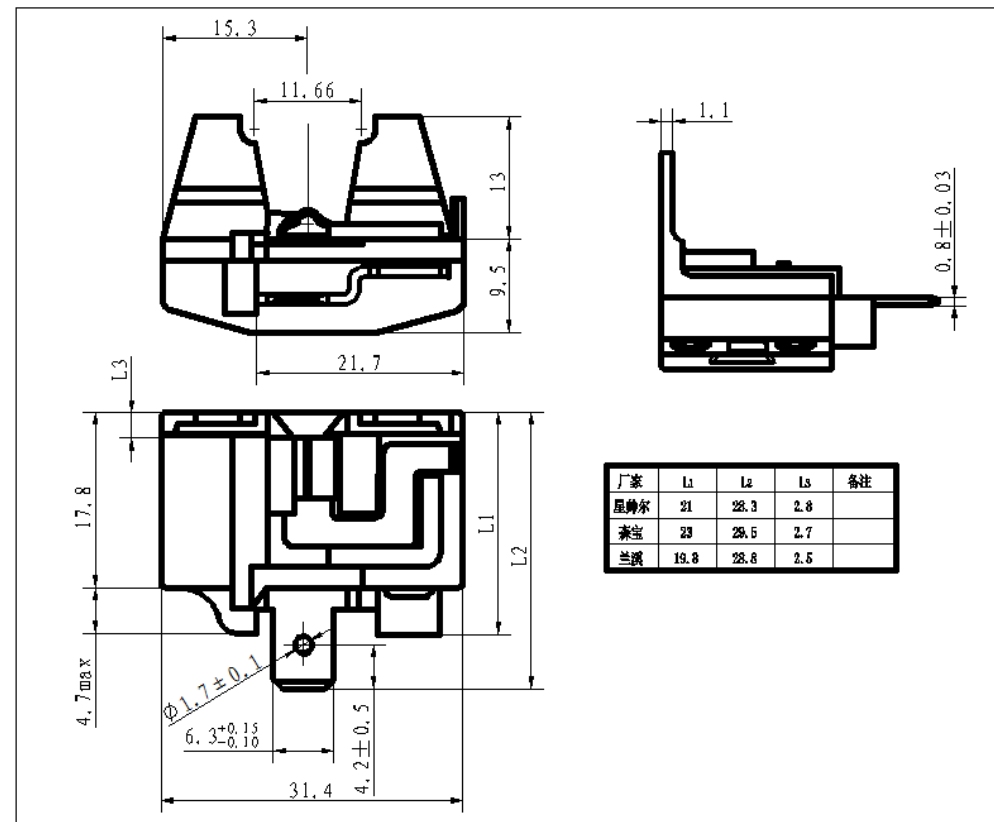

Cover & Accessories

